

# CLAMP PARTS

CP01~CP40

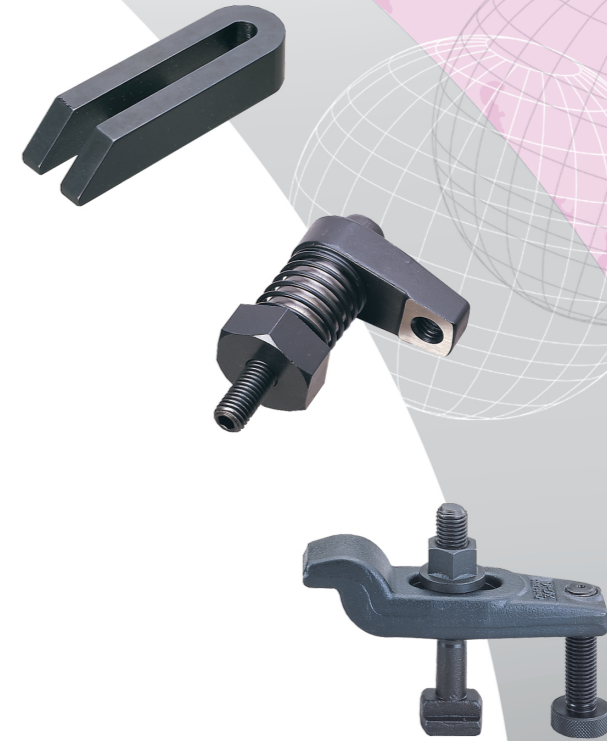

U-CLAMP TAPPED-NOSE STRAP GOOSE NECK TAPPED END U-CLAMP PLATE CLAMP

## CP01

### U-CLAMP



- Material : S45C(JIS) / CK45(DIN)
- Heat treated : HRC 32°~38°.
- Surface finish : Black Oxide.
- Features : Open end permits quick & easy installation.

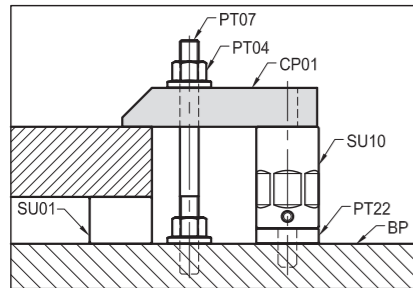
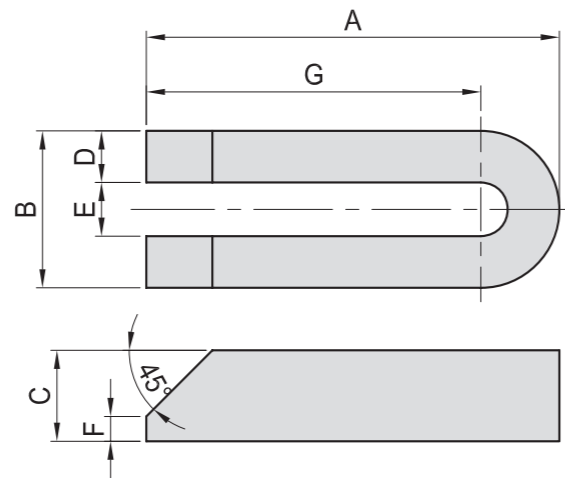

MODEL NO.	A	B	C	D	E	F	G	kg
CP01-12100	100		22				81	0.41
CP01-12125	125	38	25	12.5	13	6	106	0.58
CP01-16150	150						125	1.10
CP01-16200	200	50	32	16.5	17	8	175	1.40
CP01-16300	300						275	1.55
CP01-20200	200						170	2.10
CP01-20300	300	60	35	19.5	21	10	270	2.70
CP01-24250	250	76	48	25.0	26	18	212	3.55

## CP02

### TAPPED-NOSE STRAP



- Material : S45C(JIS) / CK45(DIN)
- Heat treated : HRC 32°~38°.
- Surface finish : Black Oxide.
- Features : The cylindrical pin minimizes contact area and is useful for clamping in horizontal holes & round profiles .

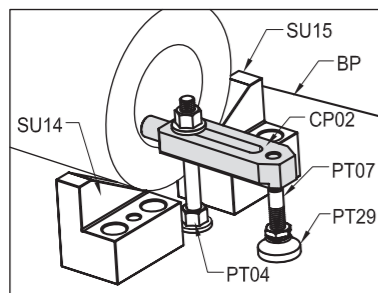
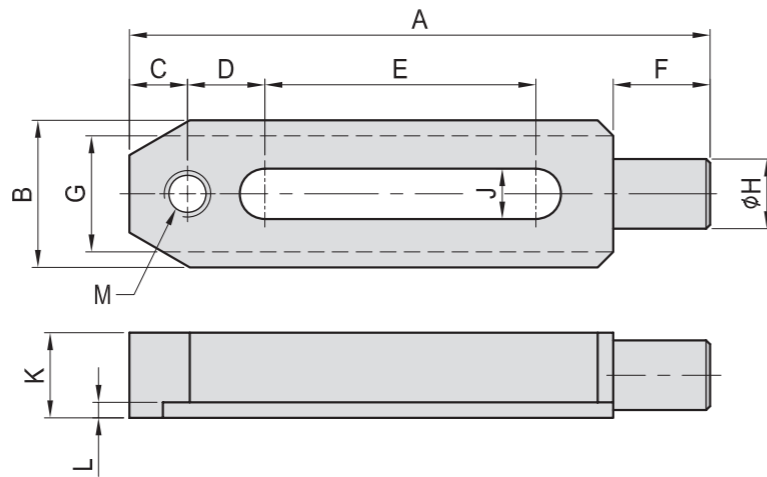

MODEL NO.	A	B	C	D	E	F	G	H	J	K	L	M	Kg
CP02-12150	150	38	15	20	70	25	30	18	13	22	4	M12	0.58
CP02-16150	150	48	20	25	40	35	40	24	17	32	5	M16	1.12
CP02-16200	200				90								1.50
CP02-20200	200				60								2.22
CP02-20250	250	60	30	35	110	40	50	28	21	35	6	M20	2.74

## CP03

### GOOSE NECK CLAMP



- Material : S45C(JIS) / CK45(DIN)
- Heat treated : HRC 32°~38°.
- Surface finish : Black Oxide.
- Features : Low profile design helps eliminate cutter interference.

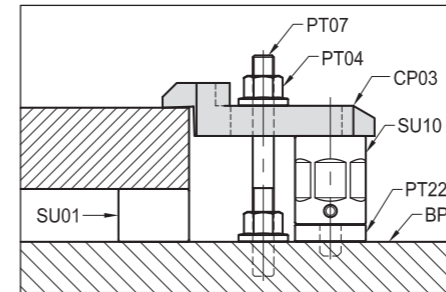
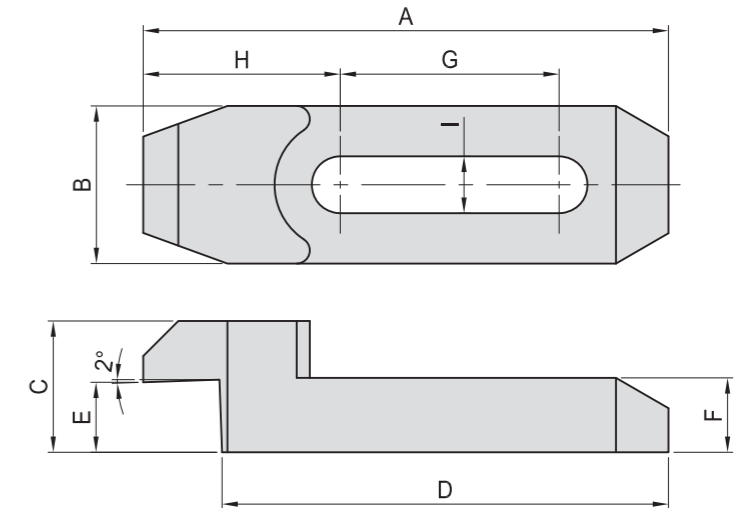

MODEL NO.	A	B	C	D	E	F	G	H	I	kg
CP03-12120	120	36	30	102	16	17	50	45	13	0.49
CP03-16150	150	48	48	130	25	25	55	60	17	1.30
CP03-20175	175	60	60	150	30	30	65	70	21	2.26

## CP04

### TAPPED END U-CLAMP



- Material : S45C(JIS) / CK45(DIN)
- Heat treated : HRC 32°~38°.
- Surface finish : Black Oxide.
- Features : Open end design permits easy assembly.

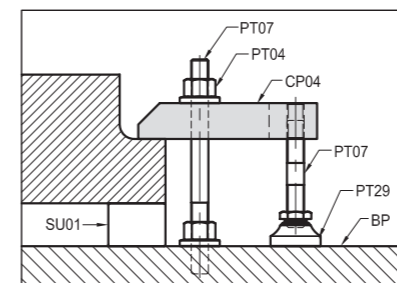
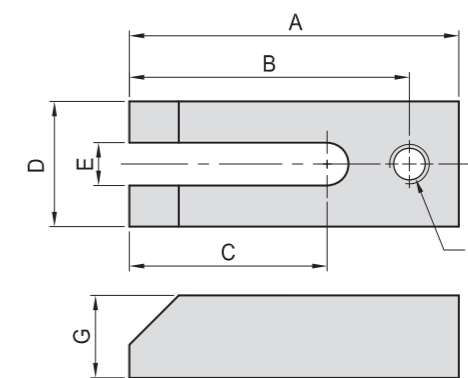

MODEL NO.	A	B	C	D	E	F	G	kg
CP04-12075	75	60	35				19	0.31
CP04-12100	100	85	60	38	13	M12	25	0.52
CP04-12125	125	110	85					0.64
CP04-14100	100	84	64	38	15	M14	25	0.39
CP04-14150	150	134	89					0.62
CP04-16100	100	80	45					0.73
CP04-16125	125	105	70	50	17	M16	25	0.90
CP04-16150	150	130	95					1.06
CP04-18150	150	130	89	50	19	M18	32	1.05
CP04-18200	200	180	127					1.45
CP04-20150	150	130	95	60	21	M20	32	1.46
CP04-20200	200	180	145					1.85

BP

BPA

BC

CP

SU

PT

SVF

ALV

OK-  
VISE

OTHER

Column  
for  
Technical  
Data

## CP05

### DOUBLE ENDED CLAMP



- Material : S45C(JIS) / CK45(DIN)
- Heat treated : HRC 32°~38°.
- Surface finish : Black Oxide.

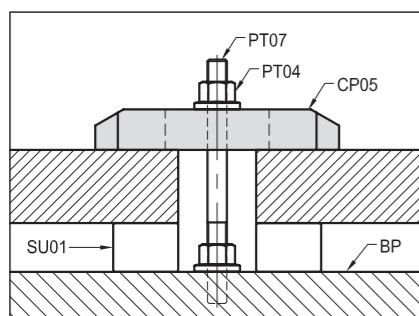
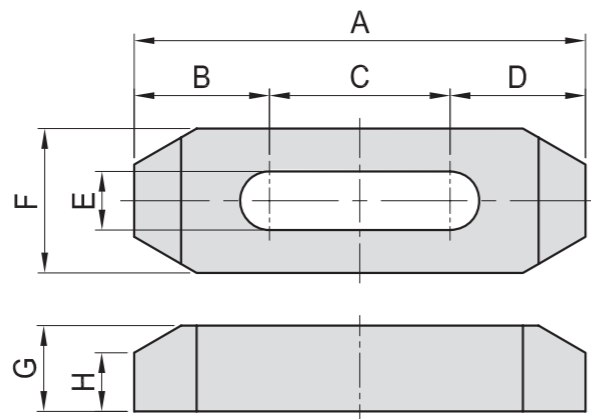

MODEL NO.	A	B	C	D	E	F	G	H	kg
CP05-12065	65	20.0	25	20.0	13	32	19	13	0.22
CP05-12100	100	30.0	40	30.0					0.33
CP05-12150	150	49.5	51	49.5	17	38	25	15	0.48
CP05-16080	80	28.0	24	28.0					0.34
CP05-16125	125	42.0	41	42.0	25	38	22	14	0.57
CP05-16150	150	51.0	48	51.0					0.68
CP05-20100	100	34.0	32	34.0	21	38	22	14	0.41
CP05-20125	125	42.5	40	42.5					0.62
CP05-20150	150	51.0	48	51.0	26	50	32	19	0.82
CP05-24150	150	51.0	48	51.0					1.14

## CP07

### SLOTTED END CLAMP STRAP



- Material : S45C(JIS) / CK45(DIN)
- Heat treated : HRC 32°~38°.
- Surface finish : Black Oxide.
- Application : Locating slot keeps clamp properly oriented.

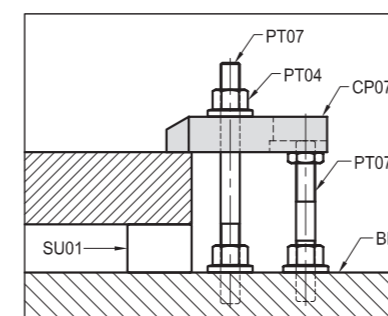
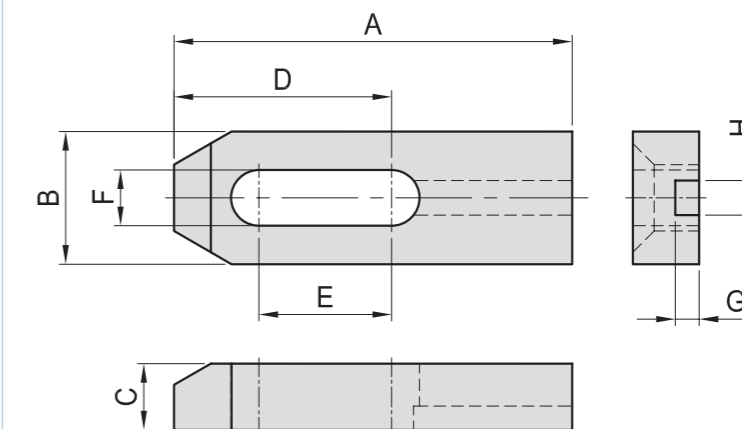

MODEL NO.	A	B	C	D	E	F	G	H	kg
CP07-12065	65	32	22	32	14	13	7	10	0.26
CP07-12080	80			48	25				0.31
CP07-12100	100	38	22	60	40	17	8	12	0.38
CP07-16080	80			40	17				0.38
CP07-16100	100	25	70	55	30	45	21	9	0.53
CP07-16125	125			70	45				0.65
CP07-20150	150	50	32	82	50	112	80	21	1.10
CP07-20200	200			80	1.40				

## CP06

### TAPPED CLAMP STRAP



- Material : S45C(JIS) / CK45(DIN)
- Heat treated : HRC 32°~38°.
- Surface finish : Black Oxide.
- Application : Use with various knobs, jack screws, clamps & pads; such as PT29.

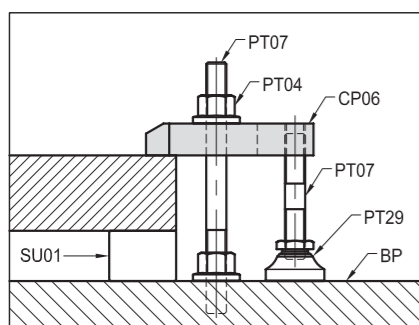
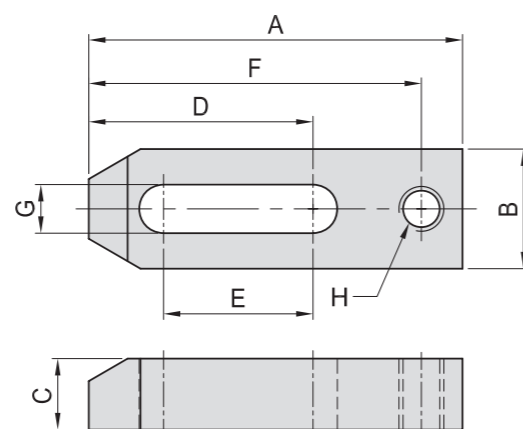

MODEL NO.	A	B	C	D	E	F	G	H	kg
CP06-12065	65	32	19	32	14	52	13	M12	0.22
CP06-12080	80			48	25	69			0.27
CP06-12100	100	38	25	60	40	89	17	M16	0.33
CP06-16080	80			40	17	65			0.32
CP06-16100	100	25	70	55	30	85	21	M20	0.53
CP06-16125	125			70	45	110			0.65
CP06-20150	150	50	32	82	50	134	80	184	1.10
CP06-20200	200			80	1.90				

## CP08

### SWING CLAMP



- Material : SCM-4(JIS)
- Heat treated : HRC 38°~42°.
- Surface finish : Black Oxide.
- Application : Multipurpose swing clamp, available with plain or threaded toe.
- Features : A small clamp with good holding power, ideal for tight spaces, full swing a way featute permits easy part loading.

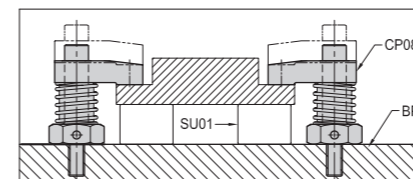
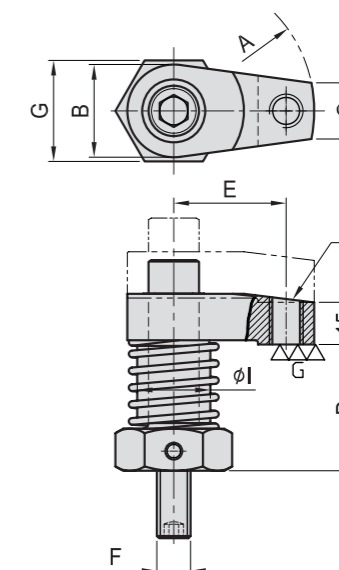

MODEL NO.	A	B	C	D	E	F	G	H	I	kg
CP08-1240-29	30	28	16	40	-	M12	29	-	22	0.29
CP08-1245-36	50	32	20	45	40	M12	36	M12	26	0.50
CP08-1645-36	50	32	20	45	40	M16	36	M12	26	0.50
CP08-1645-41	60	40	25	45	45	M16	41	M16	32	0.75

## CP09

### SWING CLAMP MOUNT/EXTENSION



- Material : S45C(JIS) / CK45(DIN)
- Heat treated : HRC 38°~42°.
- Surface finish : Black Oxide.
- Application : Use with CP10 swing clamp to gain extra height.

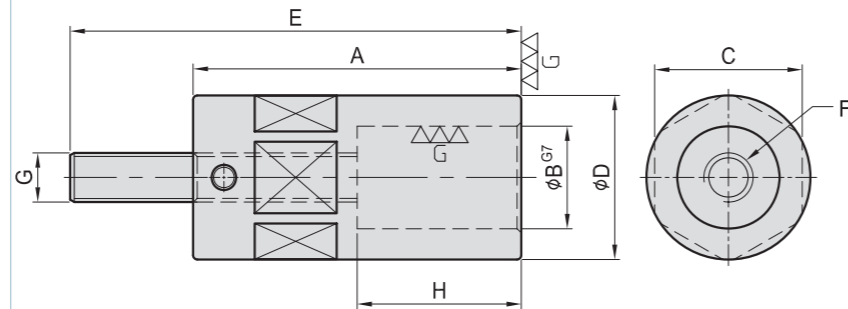

MODEL NO.	A	B	C	D	E	F	G	H	kg
CP09-12080	80	25	36	40	110	M12	M12	40	0.60
CP09-12100	100	25	36	40	130	M12	M12	40	0.78
CP09-16080	80	32	46	50	110	M16	M16	40	0.83
CP09-16100	100	32	46	50	130	M16	M16	40	1.25

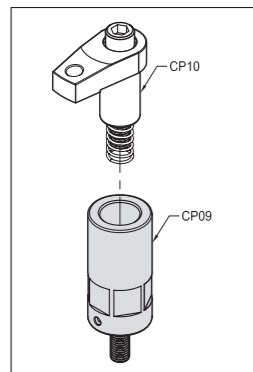

## CP10

### SWING CLAMP



- Material : SCM-4(JIS)
- Heat treated : HRC 38°~42°.
- Surface finish : Black Oxide.
- Application : Multipurpose swing clamp, available with plain or threaded toe.

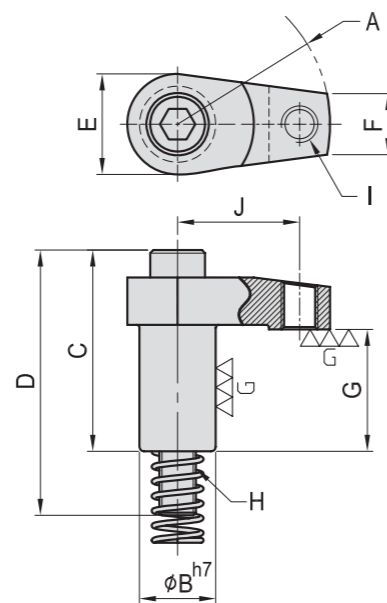

MODEL NO.	A	B	C	D	E	F	G	H	I	J	kg
CP10-1022	30	22	54.5	75	28	16	30	M10	-	-	0.20
CP10-1225	50	25	66.0	87	33	20	40	M12	M12	40	0.35
CP10-1632	60	32	69.5	96	40	26	40	M16	M12	45	0.61

Type	A	B	C	D
CP10-1022	22	30	20	M10
CP10-1225	25	40	25	M12
CP10-1632	32	40	25	M16

## CP11

### FREE JAW VISE

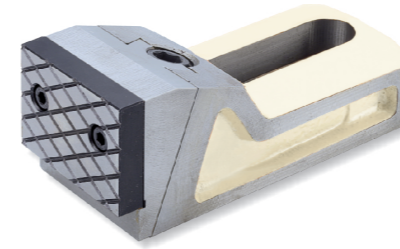

- Material : FCD 45(JIS)
- Heat treated : Nnormalized.
- Application : Ideal for holding large or irregular shapes.
- Features : Clamping force in 2 directions, available with plain or serrated jaws.

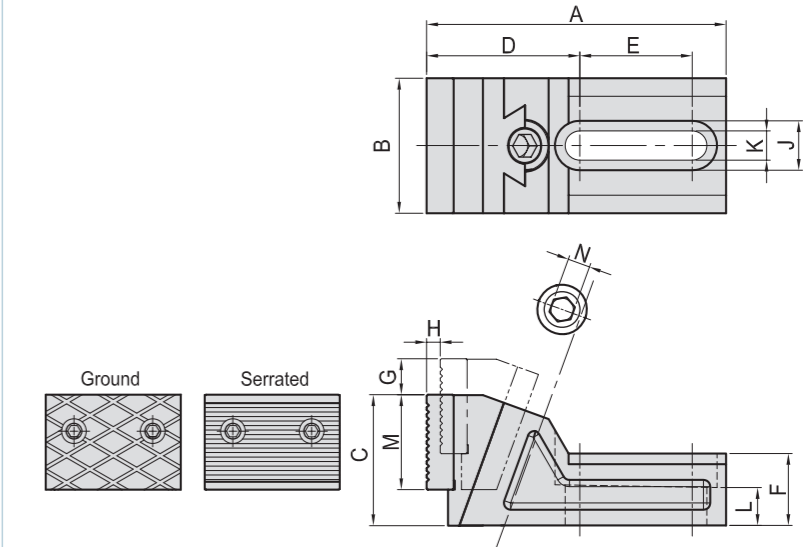
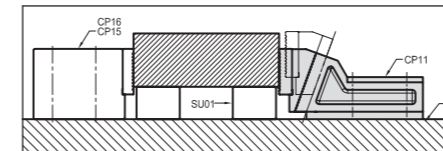

MODEL NO.	A	B	C	D	E	F	G	H	J	K	L	M	N	Type	kg
CP11-1260-G	133	60	58	68	50	32	16	6	22	13	16.8	42	10	Ground	2.1
CP11-1685-G	187	85	80	92	70	50	24	9	30	17	23.4	60	14	Ground	5.6
CP11-1260-S	133	60	58	68	50	32	16	6	22	13	16.8	42	10	Serrated	2.1
CP11-1685-S	187	85	80	92	70	50	24	9	30	17	23.4	60	14	Serrated	5.6

## CP12

### ADJUSTABLE SIDE CLAMP



- Material: S45C(JIS) / CK45(DIN)
- Heat treated : HRC 38°. Jaw Surface treated with high frequency quenching.
- Surface finish : Black Oxide.
- Application : Low profile side clamp keeps top surfaces clear for machining, ideal for rough or finished parts, available with plain or serrated jaw.

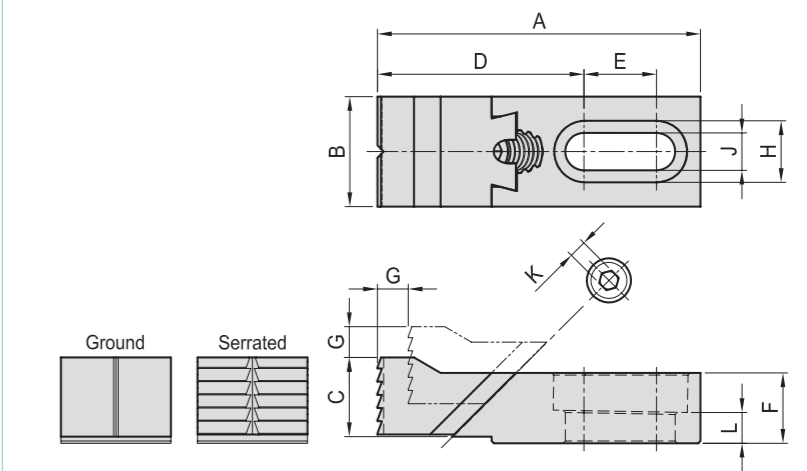
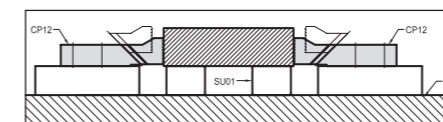

MODEL NO.	A	B	C	D	E	F	G	H	J	K	L	Type	kg
CP12-0825-G	72.0	25	18.0	45.5	16.5	16	7	14	8.5	5	7	Ground	0.18
CP12-1235-G	104.5	35	27.5	62.0	30.0	22	12	20	13.5	6	9	Ground	0.52
CP12-1640-G	133.0	40	37.5	80.5	35.0	30	14	26	17.0	8	13	Ground	1.02
CP12-0825-S	73.5	25	18.0	47.0	16.5	16	7	14	8.5	5	7	Serrated	0.18
CP12-1235-S	106.5	35	27.5	64.0	30.0	22	12	20	13.5	6	9	Serrated	0.52
CP12-1640-S	134.5	40	37.5	82.0	35.0	30	14	26	17.0	8	13	Serrated	1.02

# CP13

## ADJUSTABLE EDGE CLAMP



- Material : S45C(JIS) / CK45(DIN)
- Heat treated : HRC 38°. Jaw Surface treated with high frequency quenching.
- Surface finish : Black Oxide.
- Application : Low profile side clamp is ideal for holding thin parts and keeps top surfaces clear for machining.

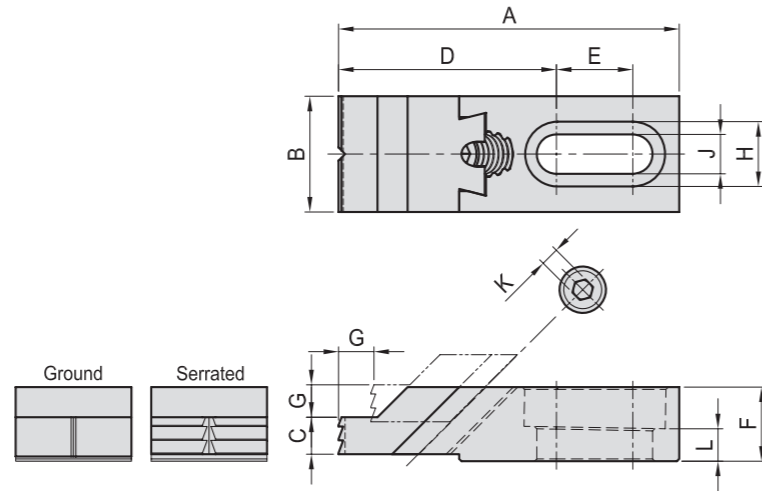

MODEL NO.	A	B	C	D	E	F	G	H	J	K	L	Type	kg
CP13-0825-G	72.0	25	8.5	45.5	16.5	16	7	14	8.5	5	7	Ground	0.15
CP13-1235-G	105.0	35	10.5	62.5	30.0	22	12	20	13.5	6	9		0.45
CP13-1640-G	133.0	40	14.0	80.5	35.0	30	14	26	17.0	8	13	Serrated	0.88
CP13-0825-S	73.5	25	8.5	47.0	16.5	16	7	14	8.5	5	7		0.15
CP13-1235-S	106.5	35	10.5	64.0	30.0	22	12	20	13.5	6	9		0.45
CP13-1640-S	134.5	40	14.0	82.0	35.0	30	14	26	17.0	8	13	0.88	

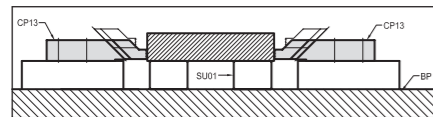

# CP14

## PIVOTING SIDE CLAMP

### CP14A

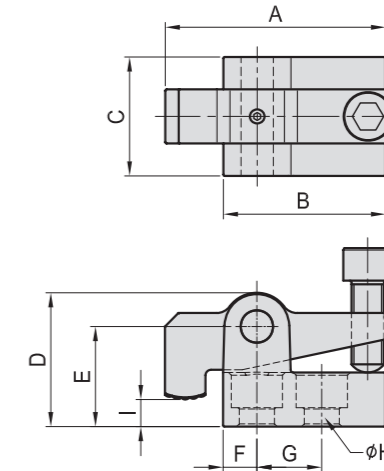

MODEL NO.	A	B	C	D	E	F	G	H	I	kg
CP14A-126045	81.5	60	44	49	37	12.5	24	13	5-15	0.78
CP14A-169068	121.0	91	68	64	47	18.0	36	18	5-15	2.26

### CP14B

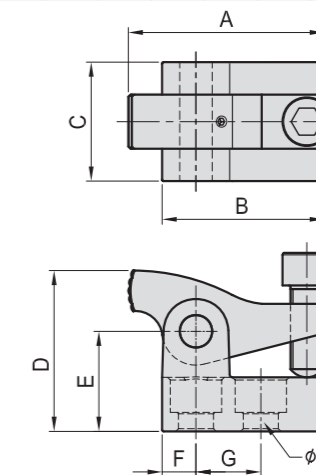

MODEL NO.	A	B	C	D	E	F	G	H	kg
CP14B-126045	72.5	60	44	59.5	37	12.5	24	13	0.73
CP14B-169068	108.0	91	68	82.0	47	18.0	36	18	2.20

### CP14C

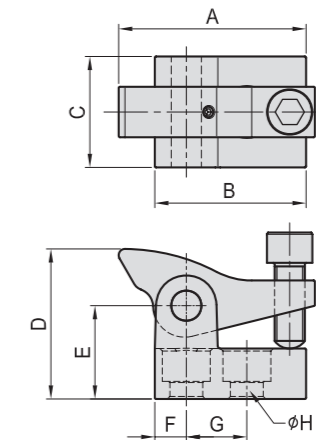

MODEL NO.	A	B	C	D	E	F	G	H	kg
CP14C-126045	75	60	44	59.5	37	12.5	24	13	0.73
CP14C-169068	110	91	68	82.0	47	18.0	36	18	2.12

- Material : S45C.
- Surface finish : Black Oxide.
- Application : Clamp that is well suited for castings and odd shaped workpieces.
- Pivoting nose has a serrated jaw that clamps forward and downward simultaneously.

BP

BPA

BC

CP

SU

PT

SVF

ALV

OK-  
VISE

OTHER

Column  
for  
Technical  
Data

## CP15

### SERRATED BLOCK STOP



- Material :  
Body : S45C(JIS)/CK45(DIN)  
jaw : YK30(JIS) / C105W1(DIN),
- Heat treated :  
Body : HRC 40°  
jaw : HRC 58°.
- Surface finish : Black Oxide.
- Application : Serrated stop is used with CP11 free vise. Useful for holding rough parts and where heavy clamping is needed.

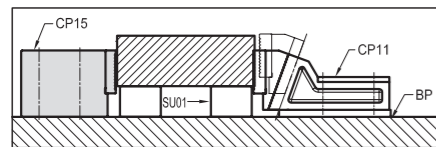
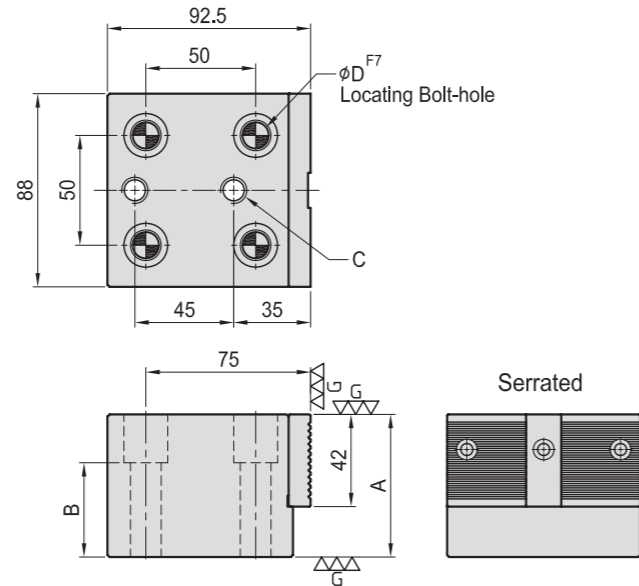

MODEL NO.	A	B	C	D	kg
CP15-1265	65	43	M12	12	3.52
CP15-1280	80	58			4.22
CP15-1665	65	38	M16	16	3.24
CP15-1680	80	53			3.78

## CP16

### SMOOTH BLOCK STOP



- Material :  
Body : S45C(JIS)/CK45(DIN)  
jaw : YK30(JIS) / C105W1(DIN),
- Heat treated :  
Body : HRC 40°  
jaw : HRC 58°.
- Surface finish : Black Oxide.
- Application : Smooth stop is used with CP11 free vise. Useful for holding finished parts.

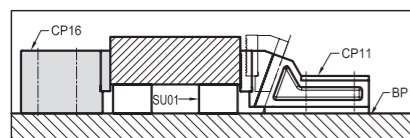
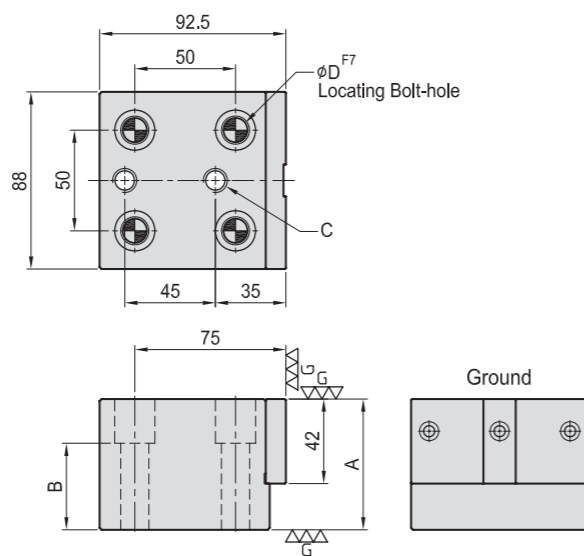

MODEL NO.	A	B	C	D	kg
CP16-1265	65	43	M12	12	3.54
CP16-1280	80	58			4.22
CP16-1665	65	38	M16	16	3.28
CP16-1680	80	53			3.78

## CP19

### FORGED SWIVEL CLAMP



- Material : S45C(JIS), Steel forging.
- Heat treated : HRC 32°~38°.
- Surface finish : Black Oxide.

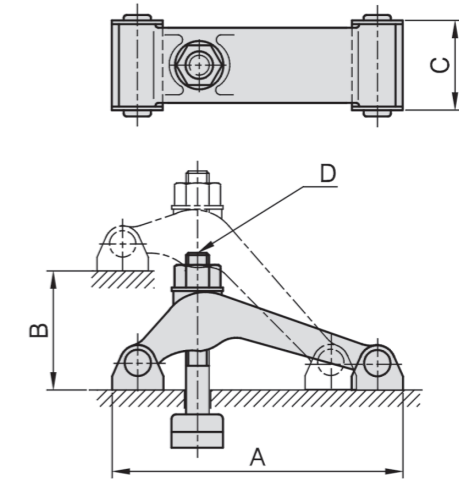

MODEL NO.	A	B	C	D	kg
CP19-12125	131	75	46.5	M12-125	1.50
CP19-16150	156	85	55.0	M16-150	2.64
CP19-20194	201	105	62.0	M20-175	4.80

## CP20

### FORGED SWIVEL CLAMP



- Material : S45C(JIS), Steel forging.
- Heat treated : HRC 32°~38°.
- Surface finish : Black Oxide.

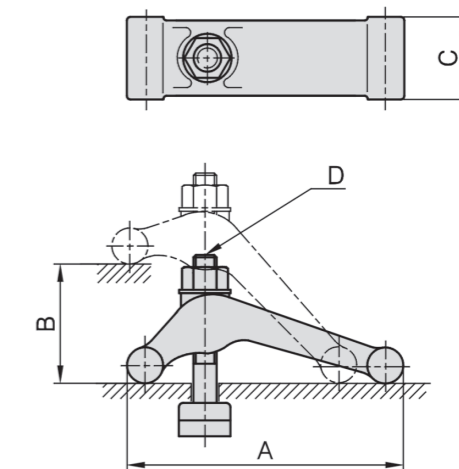

MODEL NO.	A	B	C	D	kg
CP20-12125	125	75	45	M12-125	1.40
CP20-16150	150	85	52	M16-150	2.42
CP20-20194	194	105	58	M20-175	4.50

## CP21

### UNIVERSAL CLAMP



- Material : S45C(JIS), Forging.
- Heat treated : HRC 32°~38°.
- Surface finish : Black Oxide.

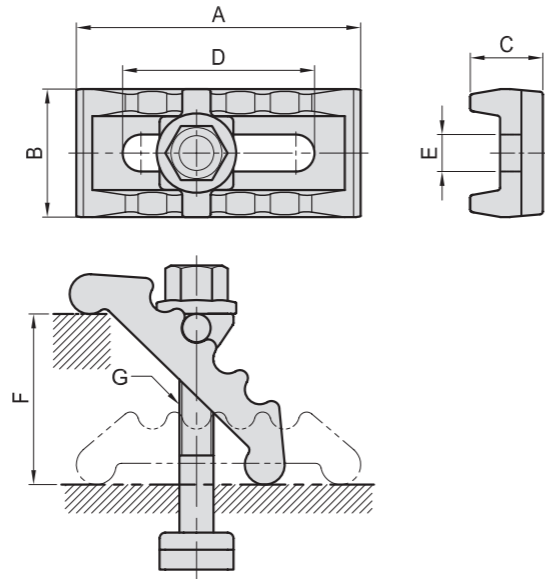

MODEL NO.	A	B	C	D	E	F	G	kg
CP21-12100	100	45	26	67.5	13	60	M12-100	1.1
CP21-16125	125	56	33	84.0	18	65	M16-125	2.1

## CP23

### FREE VISE



- Material Heat Treated and surface to be treated with Black Oxide.

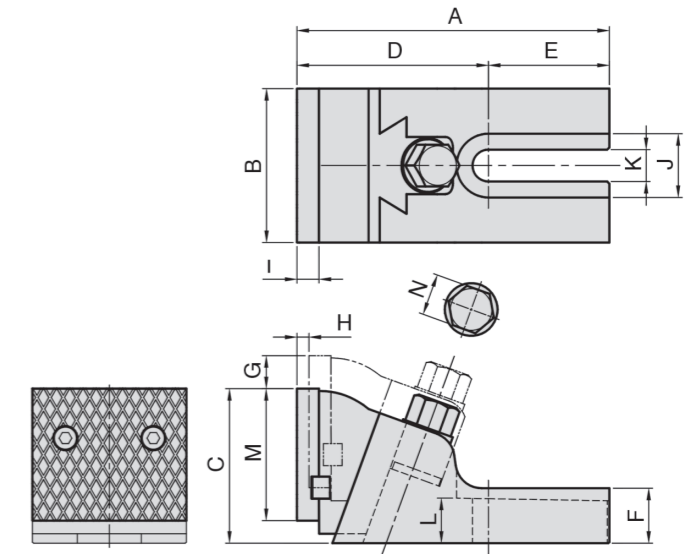

MODEL NO.	A	B	C	D	E	F	G	H	I	J	K	L	M	N	kg
CP23-12140	142	70	70	87	55	25	14	5	10	29	14.5	20.5	60	19	6.3
CP23-16195	192	85	85	103	88	30	15	5	12	37	17.0	24.0	70	24	11.0
CP23-20220	220	110	104	120	100	36	20	7	13	42	21.0	28.0	85	30	21.0

## CP22

### T-SLOT MINIATURE CLAMP



- Material : S45C (JIS)
- Heat treated : HRC 35°~38°.

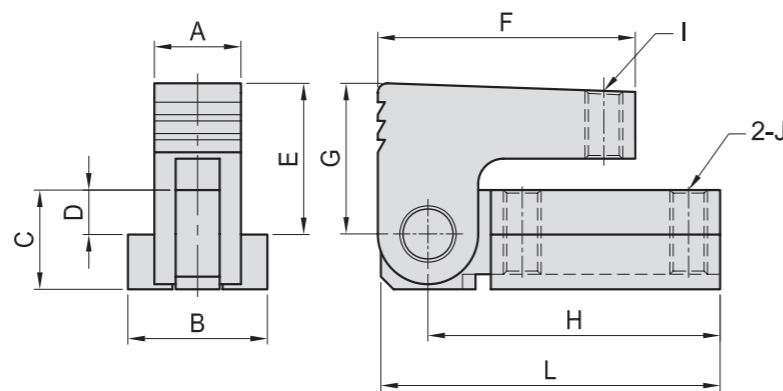

MODEL NO.	A	B	C	D	E	F	G	H	I	L	J	kg
CP22-1218	10.8	17.5	12.7	7.2	23.2	41	22.0	48.0	M6	54.0	M6	0.10
CP22-1422	13.8	22.2	15.8	7.1	24.1		24.0	46.0				
CP22-1625	15.8	25.4	15.8	7.1	27.1	50	27.0	55.0	M8	65.0	M8	0.22
CP22-1828	17.5	28.5	19.0	7.9	28.9		29.0					
CP22-2032	19.7	31.7	25.4	11.4	33.9	50	34.0	55.0	M10	65.0	M10	0.40
CP22-2240	21.7	38.0	28.0	12.8	39.8	65	39.5	71.0			81.5	M12
CP22-2841	27.5	46.7	44.0	25.0	49.0	71	49.0	72.5	M16	130.0	M16	1.20
CP22-3559	34.7	55.0	48.0	24.5	64.0	103	62.5	113.5				

## CP24

### ECCENTRIC CAM LOCK



- Material : S45C (JIS)
- Heat treated : HRC 35°(ECCENTRIC CAM)

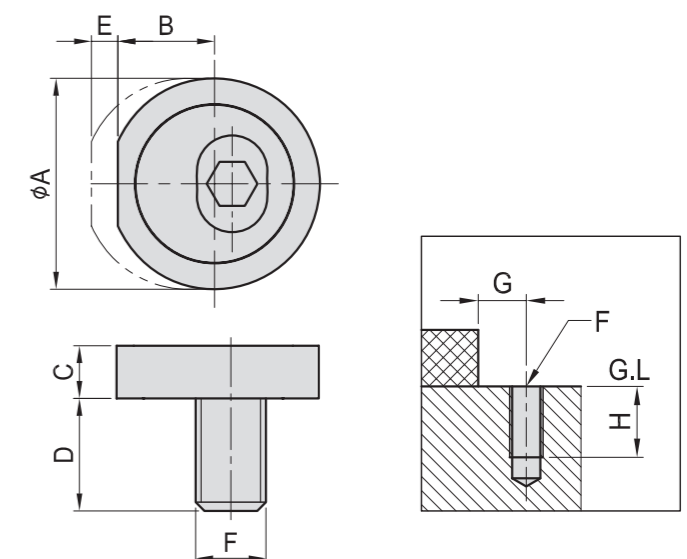

MODEL NO.	A	B	C	D	E	F	G	H	kg
CP24-0824	24	11.0	6	12.8	3	M 8	11.5	17	0.020
CP24-1026	26	11.8	8	14.3	4	M10	12.5	22	0.030
CP24-1230	30	13.5	9	17.8	5	M12	14.5	22	0.050
CP24-1638	38	16.0	12	20.8	6	M16	17.5	26	0.115

# CP25

## STEP CLAMP

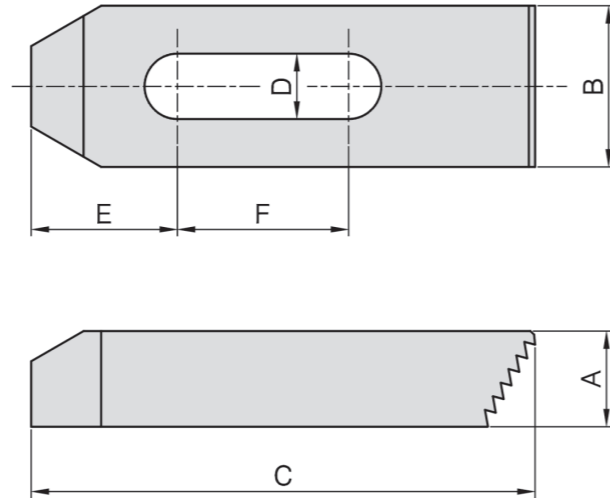

- Material : S45C
- Heat treated : HRC 32°~38°.
- Surface finish : Black Oxide.
- Application : Used with SU25.

MODEL NO.	A	B	C	D	E	F	kg
CP25-10063	13	25	63	11	18	19	0.100
CP25-10100	16	25	100		27	37	0.215
CP25-10150	19	32	150		30	50	0.570
CP25-12063	13	25	63	13	20	14	0.100
CP25-12100	19	32	100		29	34	0.320
CP25-12150	22	32	150		32	50	0.650
CP25-14063	13	25	63	15	20	14	0.100
CP25-14100	19	32	100		29	34	0.315
CP25-14150	22	32	150		32	50	0.600
CP25-16063	16	32	63	17	22	12	0.160
CP25-16100	19	38	100		31	26	0.400
CP25-16150	22	38	150		40	47	0.710
CP25-18063	16	32	63	20	22	12	0.140
CP25-18100	19	38	100		31	26	0.380
CP25-18150	22	38	150		40	47	0.750
CP25-20100	19	38	100	21	31	26	0.360
CP25-20150	25	38	150		43	44	0.750
CP25-20200	25	50	200		55	65	1.500
CP25-24150	32	50	150	26	43	38	1.290
CP25-24200	32	50	200		53	57	2.000
CP25-24250	38	50	250		60	64	2.950



# CP27

## THREADED GOOSE NECK CLAMP

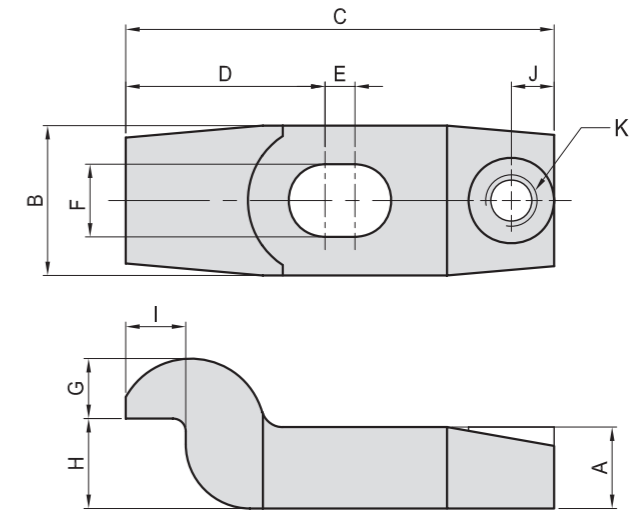

- Material : S45C(JIS), Forging.
- Surface finish : Black Oxide.

MODEL NO.	A	B	C	D	E	F	G	H	I	J	K	kg
CP27-16100	19	35	100	46.5	7	17	14	21	14	10	M12x1.75	0.78
CP27-16150	22	45	150	62.0	26	17	15	24	22	12	M16x2.00	1.70

# CP28

## GOOSE NECK CLAMP



- Material : S45C(JIS), steel forging.
- Surface finish : Black Oxide.

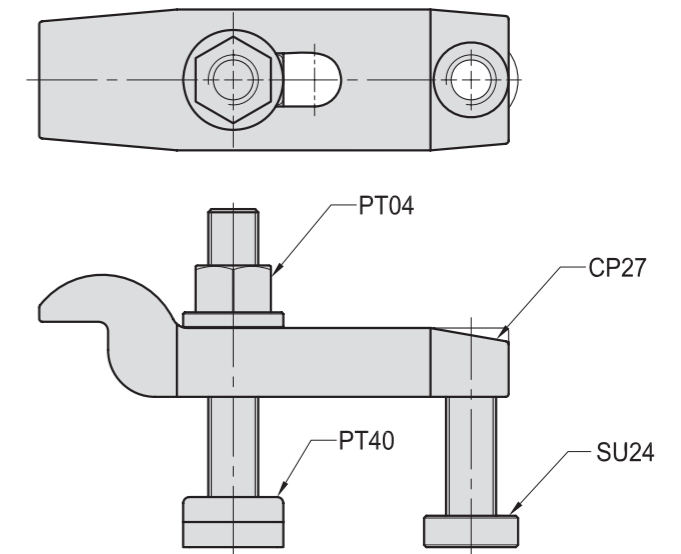

MODEL NO.	CP27	PT40	PT04	SU24	kg
CP28-ZC-40	16100	16100	1624	12060	1.5
CP28-ZC-60	16150	16100	1624	16070	2.6

BP

BPA

BC

CP

SU

PT

SVF

ALV

OK-  
VISE

OTHER

Column  
for  
Technical  
Data



## CP29

### BLOCK STOP



- Material : S45C
- Heat treated : HRC 32°~38°
- Surface finish : Black Oxide.
- Application : used with CP12.

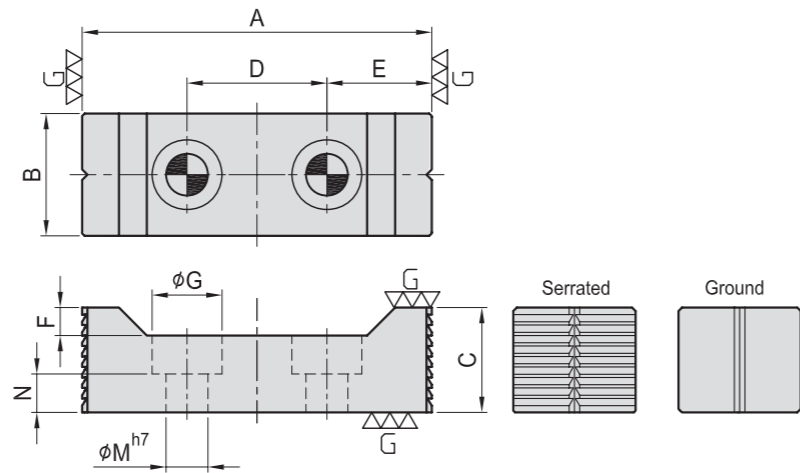

MODEL NO.	A	B	C	D	E	F	G	M	N	kg	TYPE
CP29-12100-S	100	35	30	40	30	8	20	12	11	0.59	Serrated
CP29-16130-S	130	40	40	50	40	10	26	16	14	1.20	
CP29-12100-G	100	35	30	40	30	8	20	12	11	0.59	Ground
CP29-16130-G	130	40	40	50	40	10	26	16	14	1.20	

## CP31

### CLAMPING PARTS

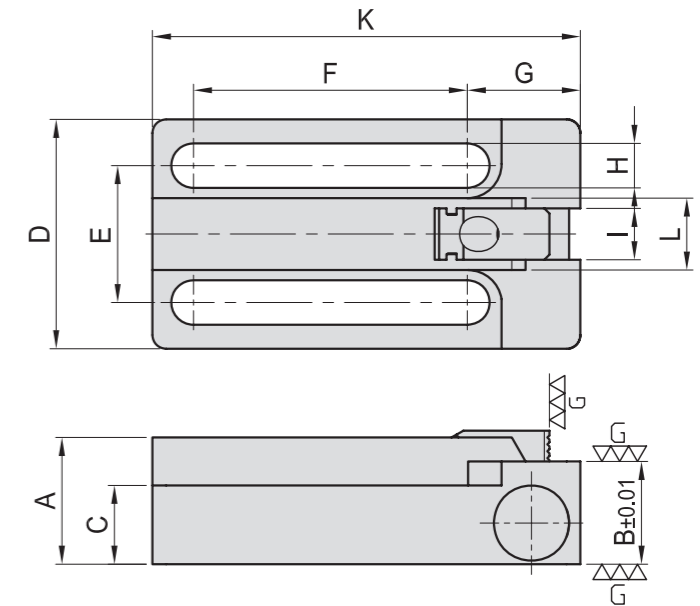

MODEL NO.	A	B	C	D	E	F	G	H	I	K	L	kg
CP31-1240	37	30	23	67	40	80	33.0	13.0	15	125	21	1.36
CP31-1250				77	50	85	33.0	13.0				1.71
CP31-1650				77	50	85	34.5	16.5				1.54

## CP30

### THIN BLOCK STOP



- Material : S45C
- Heat treated : HRC 32°~38°
- Surface finish : Black Oxide.
- Application : used with CP13.

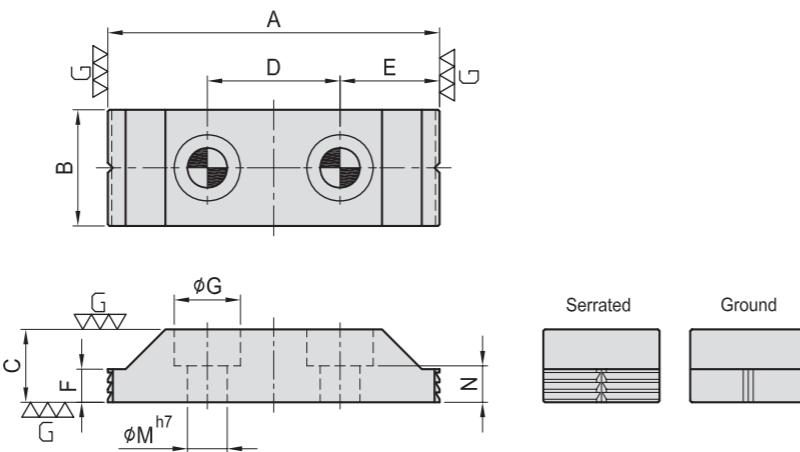

MODEL NO.	A	B	C	D	E	F	G	M	N	kg	TYPE
CP30-12100-S	100	35	22	40	30	10	20	12	11	0.46	Serrated
CP30-16130-S	130	40	30	50	40	14	26	16	14	0.88	
CP30-12100-G	100	35	22	40	30	10	20	12	11	0.46	Ground
CP30-16130-G	130	40	30	50	40	14	26	16	14	0.88	

## CP32

### BLOCK STOP

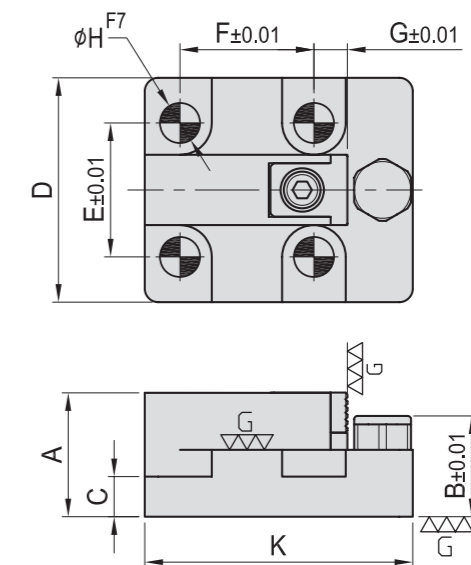

MODEL NO.	A	B	C	D	E	F	G	H	K	kg
CP32-1240	37	30	12	67	40	40	10	12	80	0.86
CP32-1250			12	77	50	50		12	95	1.19
CP32-1650			15	77	50	50		16	95	1.14

## CP33

### CLAMPING PARTS

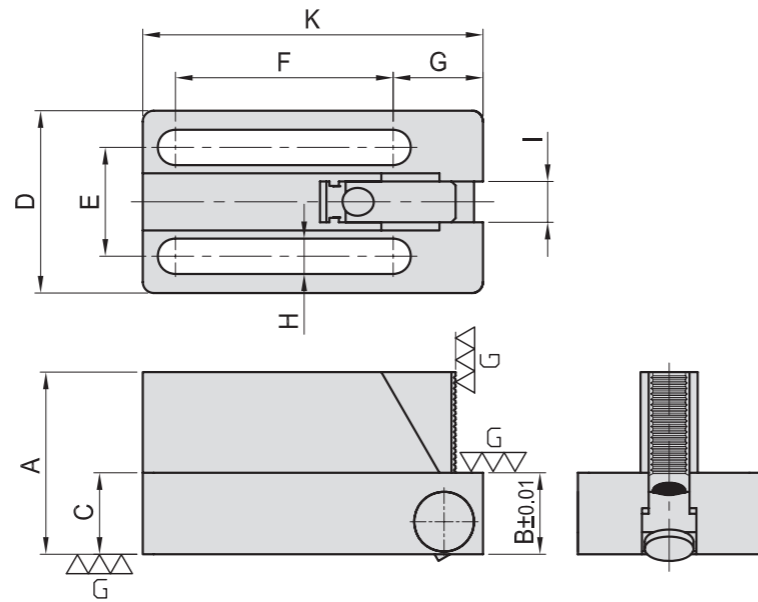
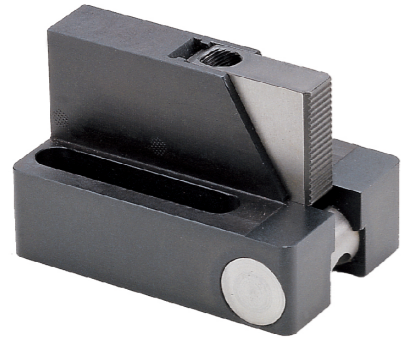

MODEL NO.	A	B	C	D	E	F	G	H	I	K	kg
CP33-1240				67	40	80	33.0	13.0		125	2.02
CP33-1250	67	30	30	77	50	85	33.0	13.0	15	130	2.45
CP33-1650				77	50	85	34.5	16.5		130	2.25

## CP34

### BLOCK STOP

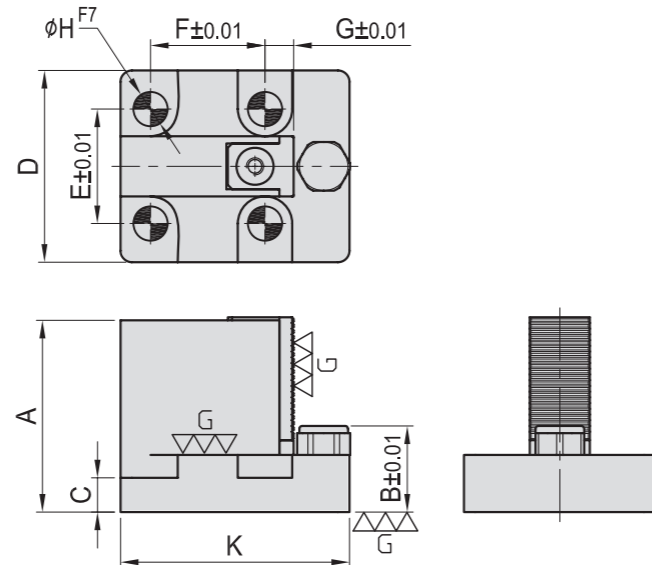

MODEL NO.	A	B	C	D	E	F	G	H	K	kg	
CP34-1240				12	67	40	40		12	80	1.24
CP34-1250	67	30		12	77	50	50	10	12	95	1.60
CP34-1650				15	77	50	50		16	95	1.52

## CP35

### REPLACEMENT HARD-JAW

#### CP35A

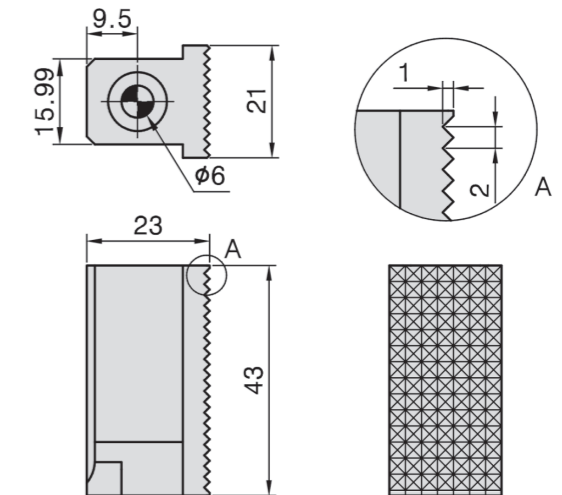
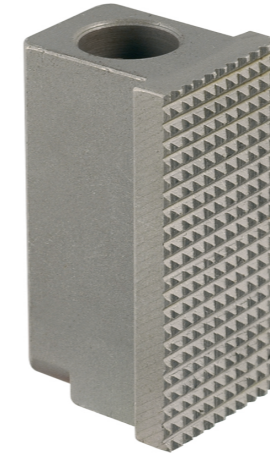

MODEL NO.	kg
CP35A-2143	0.12

#### CP35B

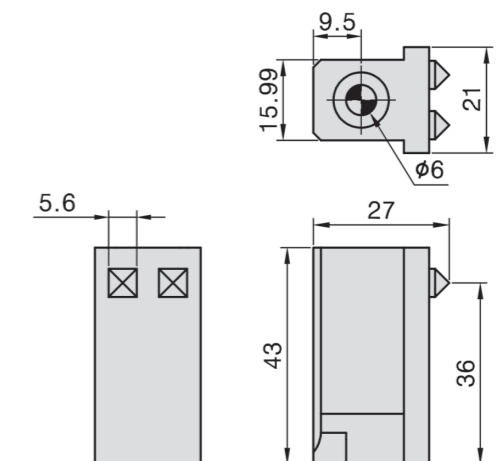
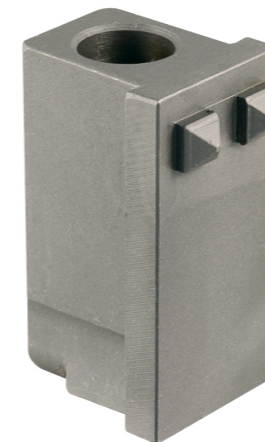

MODEL NO.	kg
CP35B-2143	0.12

BP

BPA

BC

CP

SU

PT

SVF

ALV

OK-  
VISE

OTHER

Column  
for  
Technical  
Data

# CP36

## REPLACEMENT HARD-JAW

CP36A

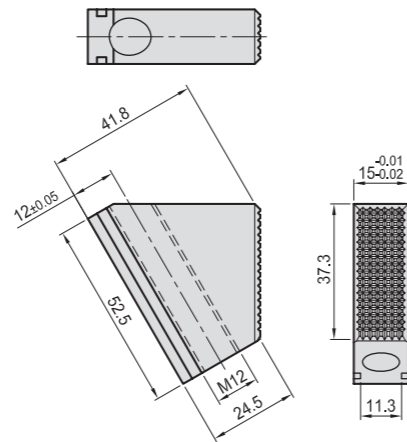

MODEL NO.	kg
CP36A-1243	0.14

CP36B

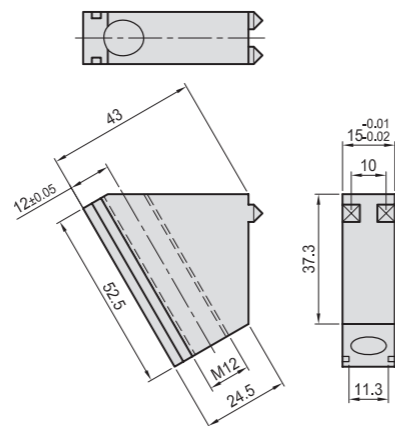

MODEL NO.	kg
CP36B-1243	0.14

CP36C

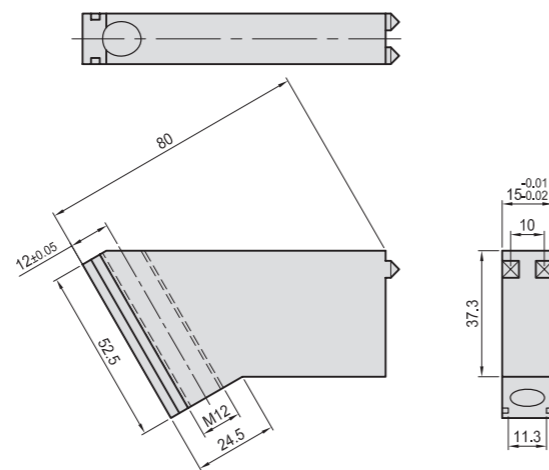

MODEL NO.	kg
CP36C-1280	0.30



# CP37

## POSITIONING EDGE SUPPORT

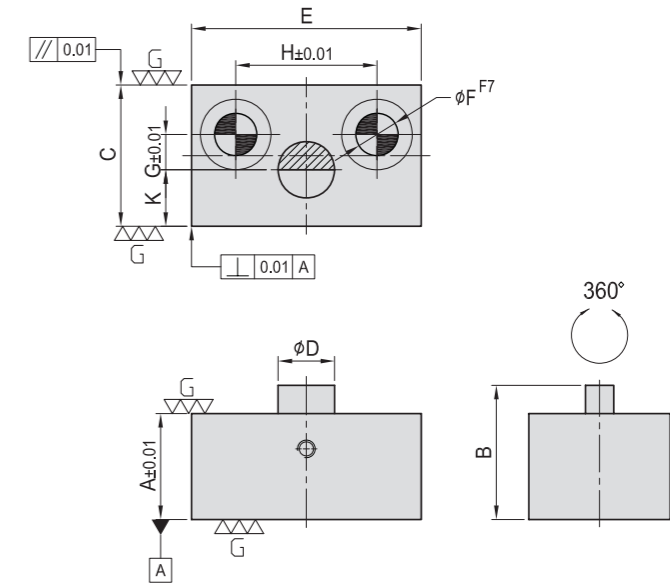

MODEL NO.	A	B	C	D	E	F	G	H	K	kg
CP37-1240			40		65	12		40	16	0.60
CP37-1250	30	38	40	16	75	12	10	50	15	0.60
CP37-1650			45		80	16		50	18	0.65

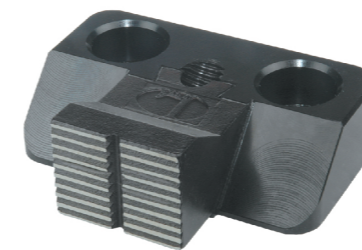

# CP38

## ADJUSTABLE SIDE CLAMP

- Material : S45C(JIS) / CK45(DIN)
- Heat treated : HRC 38°. Jaw Surface treated with high frequency quenching.
- Surface finish : Black Oxide.
- Application : Low profile side clamp keeps top surfaces clear for machining, ideal for rough or finished parts, available with plain or serrated jaw.

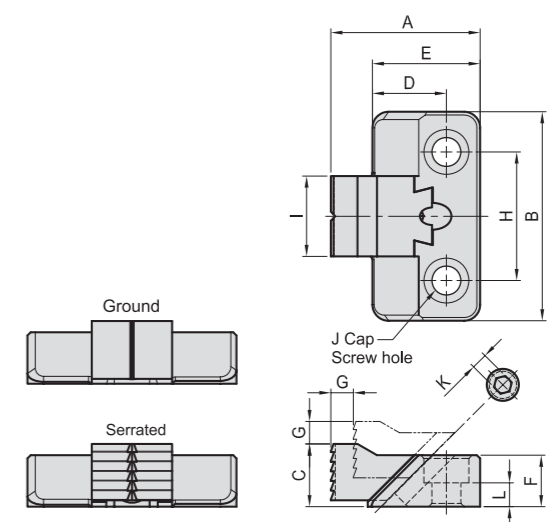

MODEL NO.	A	B	C	D	E	F	G	H	I	J	K	L	Type	kg
CP38-0865-G	45.14	65	19.5	23	33.5	16	7	40	25	M 8	5	7.4	Ground	0.22
CP38-1285-G	65.14	85	29.0	33	48.0	22	12	50	35	M12	6	9.0	Ground	0.65
CP38-16100-G	85.64	100	39.0	48	68.0	30	14	50	40	M16	8	12.5	Ground	1.40
CP38-0865-S	46.45	65	19.5	23	33.5	16	7	40	25	M 8	5	7.4	Serrated	0.22
CP38-1285-S	67.14	85	29.0	33	48.0	22	12	50	35	M12	6	9.0	Serrated	0.65
CP38-16100-S	87.14	100	39.0	48	68.0	30	14	50	40	M16	8	12.5	Serrated	1.40

BP

BPA

BC

CP

SU

PT

SVF

ALV

OK-VISE

OTHER

Column for Technical Data

# CP39

## ADJUSTABLE SIDE CLAMP



- Material : S45C(JIS) / CK45(DIN)
- Heat treated : HRC 38°. Jaw Surface treated with high frequency quenching.
- Surface finish : Black Oxide.
- Application : Low profile side clamp keeps top surfaces clear for machining, ideal for rough or finished parts, available with plain or serrated jaw.

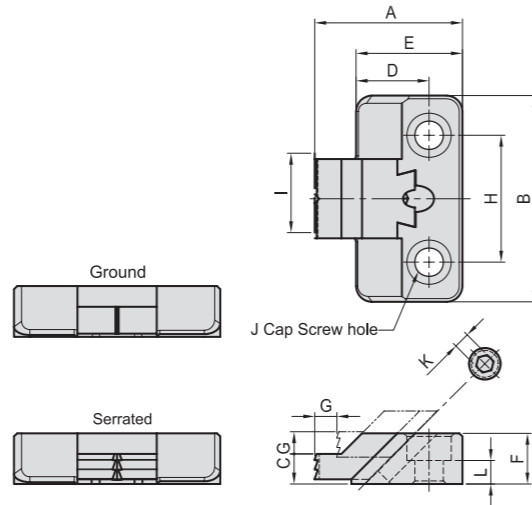

MODEL NO.	A	B	C	D	E	F	G	H	I	J	K	L	Type	kg
CP39-0865-G	45.14	65	9.5	23	33.5	16	7	40	25	M 8	5	7.4	Ground	0.2
CP39-1285-G	65.64	85	12.0	33	48.0	22	12	50	35	M12	6	9.0		0.6
CP39-16100-G	86.14	100	15.5	48	68.0	30	14	50	40	M16	8	12.5		1.3
CP39-0865-S	46.55	65	9.5	23	33.5	16	7	40	25	M 8	5	7.4	Serrated	0.2
CP39-1285-S	67.14	85	12.0	33	48.0	22	12	50	35	M12	6	9.0		0.6
CP39-16100-S	87.64	100	15.5	48	68.0	30	14	50	40	M16	8	12.5		1.3

# CP40

## MACHINABLE IRREGULAR CLAMPS



- Material : Soft Jaw : A6061, Base : S45C(JIS)
- Surface finish : Soft Jaws : Anodic Treatment
- Heat treated : Base : HRC 25°~ 30°
- Application : Vertical Machining Center
- Features : Hold the irregular clamps of aluminum and copper.

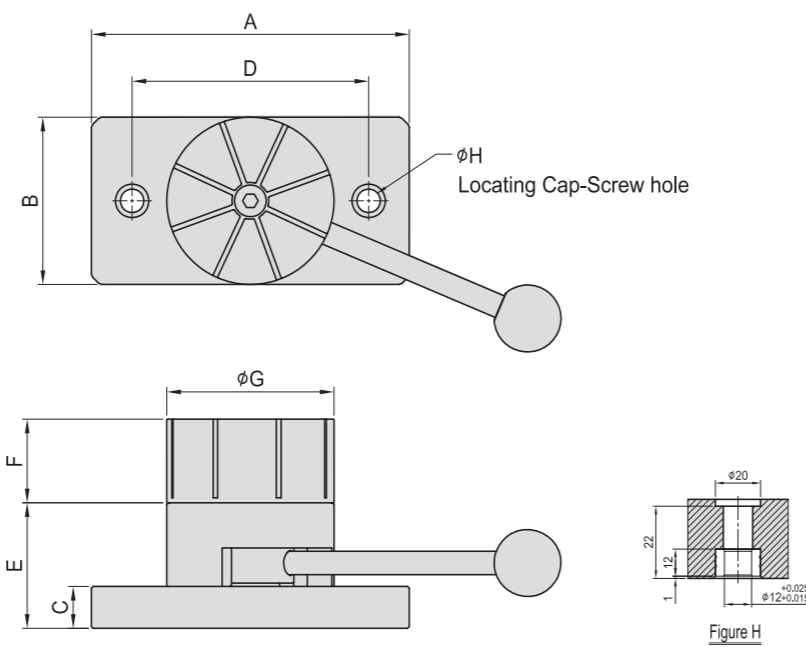

MODEL NO.	A	B	C	D	E	F	G	H	kg
CP40-A100	190	100	25	141.42	75	50	100	12	7.5