

8-M16
Cap-Screw hole
(Figure A)

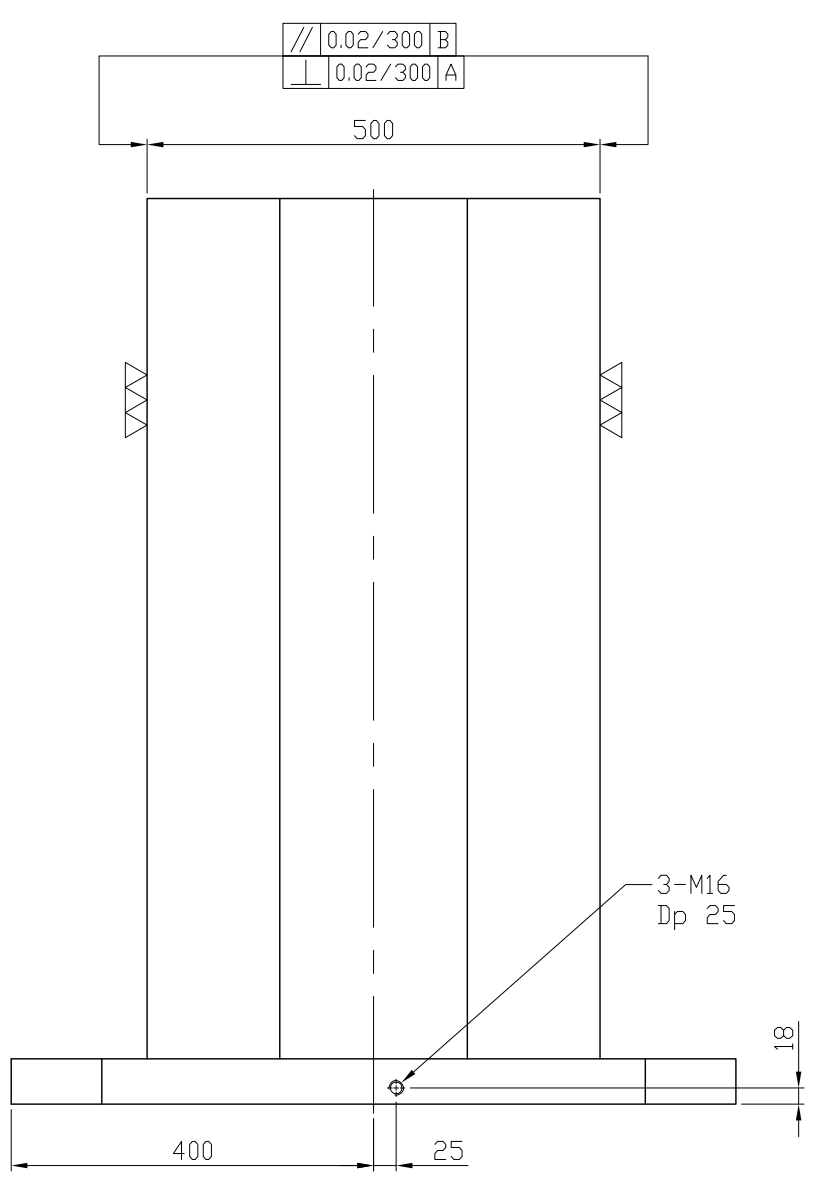
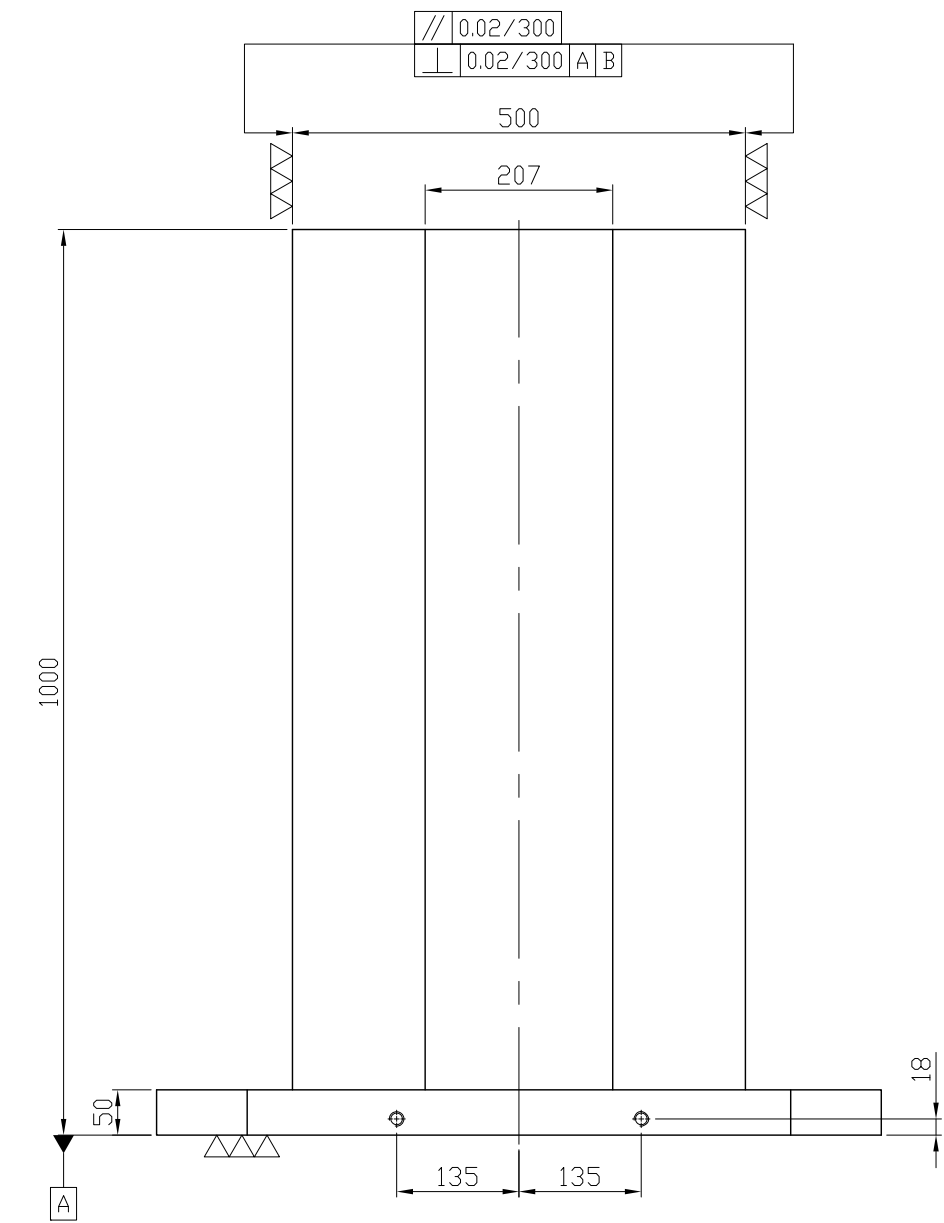

*Edge chamfered C2

NW:711KG

Material FC300		Heat treatment Annealing Process			Surface treatment			
Drafted by S.C.H	Checked by	Approved by		Scale 1/1	Date 2011.12.22	Sheet 1/1	Edition A	
			TITLE M/C OCTAGONAL CUBE					
			DWG.NO. BP33-800800-1000					