

4-M12
Inserted
(Figure C)

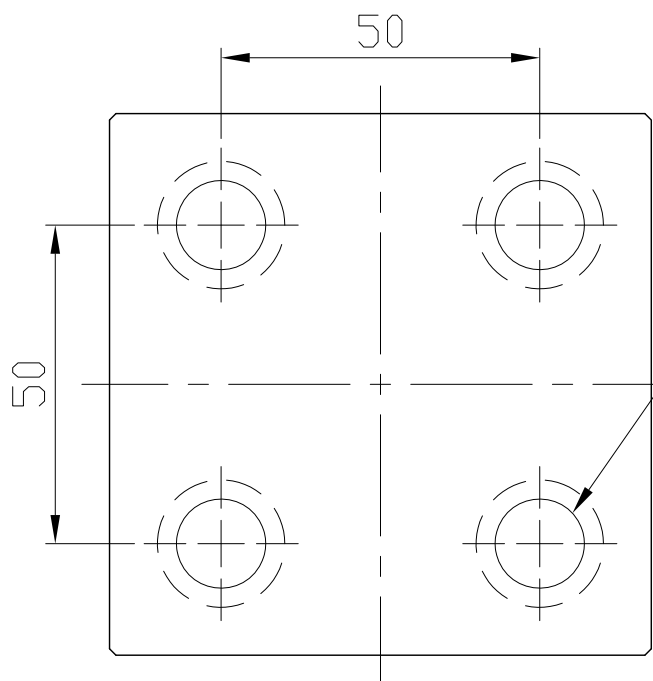

4-M12
Cap-Screw hole
(Figure A)

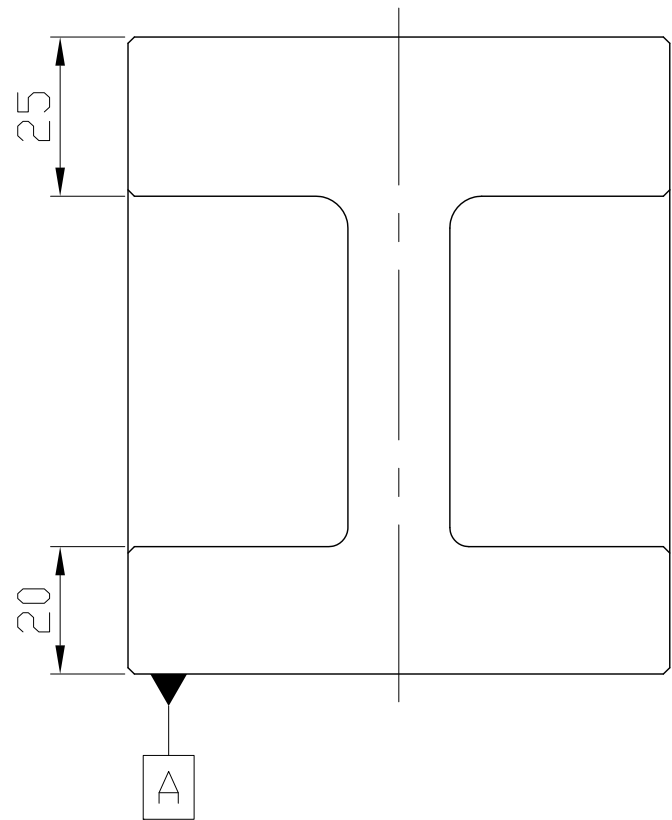
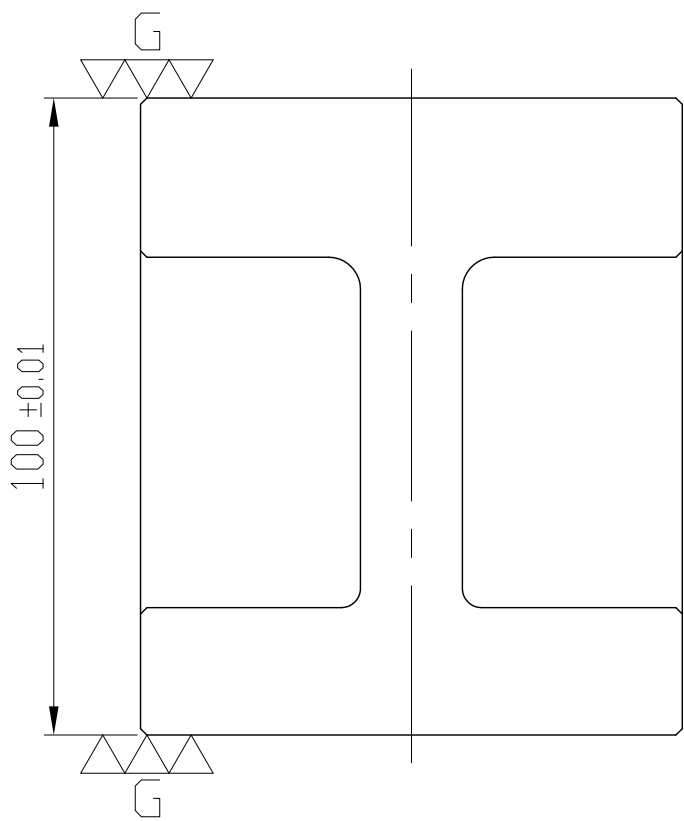
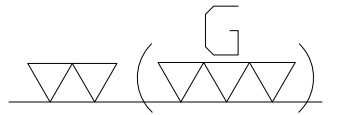
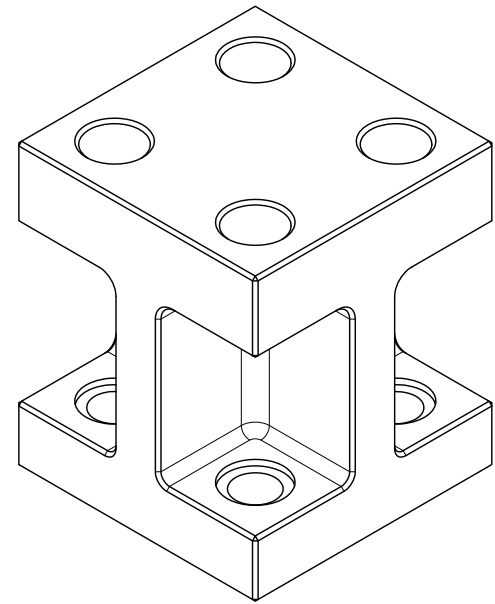
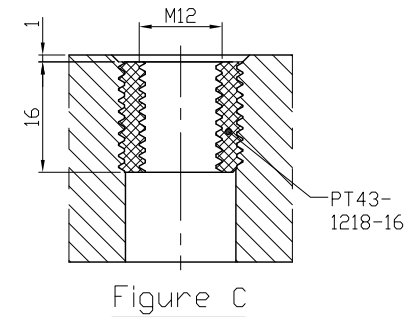
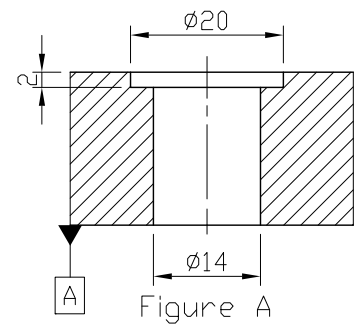

*Edge chamfered C1

NW:3.64KG

| | | | | | | | |
|---------------------|------------|-------------------------------------|--------------------------------|--------------------|-------------------|--------------|--|
| Material FC300 | | Heat treatment Annealing Process | | | Surface treatment | | |
| Drafted by KENZI | Checked by | Approved by | Scale 1/1 | Date 2014.11.18 | Sheet 1/1 | Edition A | |
| | | | TITLE H/CAST SECTION | | | | |
| | | | DWG.ND. BP35-085085-0100-12 | | | | |