

4-M12
Inserted
(Figure C)

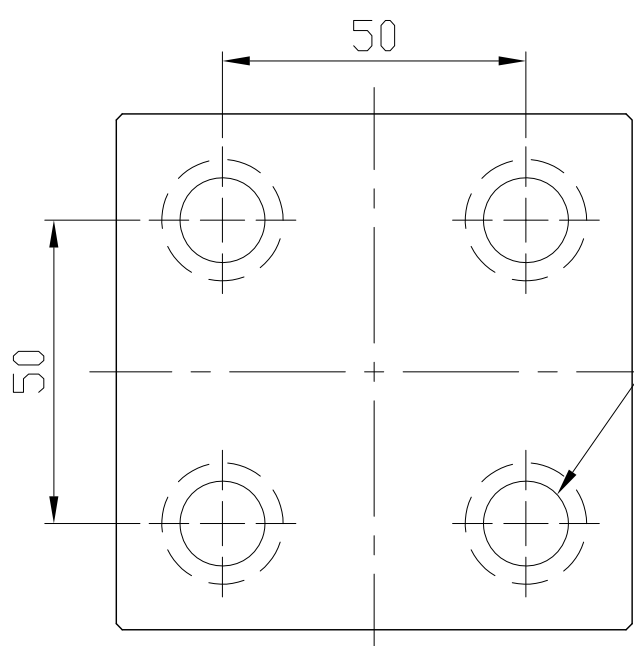

4-M12
Cap-Screw hole
(Figure A)

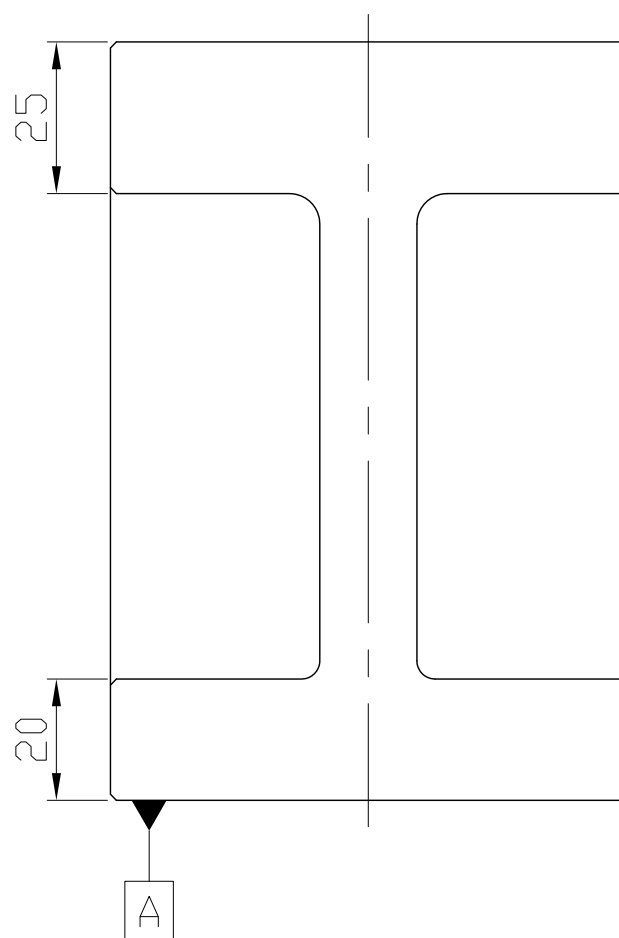
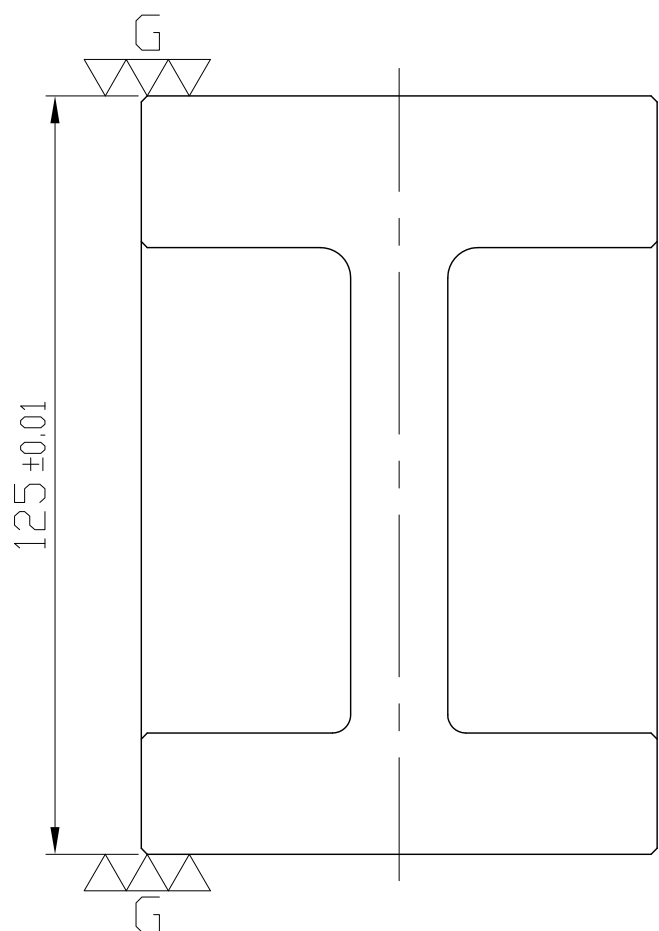
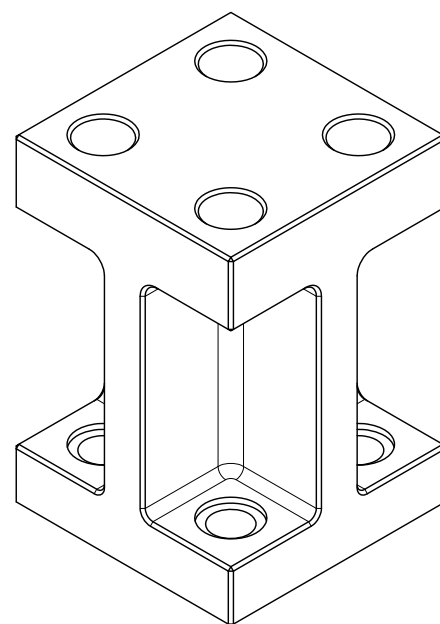
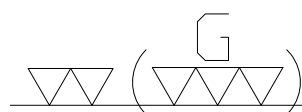
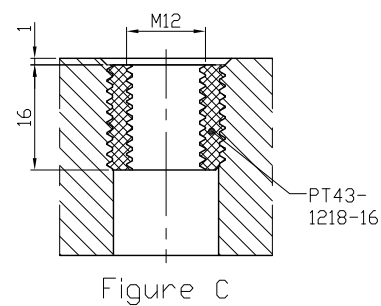
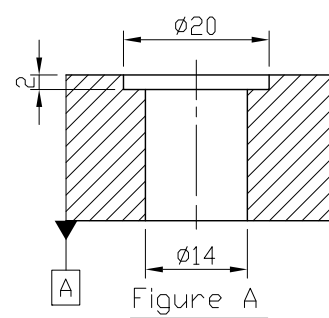

*Edge chamfered C1

NW:4.13KG

Material FC300		Heat treatment Annealing Process			Surface treatment		
Drafted by KENZI	Checked by	Approved by	Scale 1/1	Date 2014.11.18	Sheet 1/1	Edition A	
			TITLE H/CAST SECTION				
			DWG.NO. BP35-085085-0125-12				