

1 2 3 4 5 6 7 8 9 10 11 12 13 14 15 16 17 18 19 20

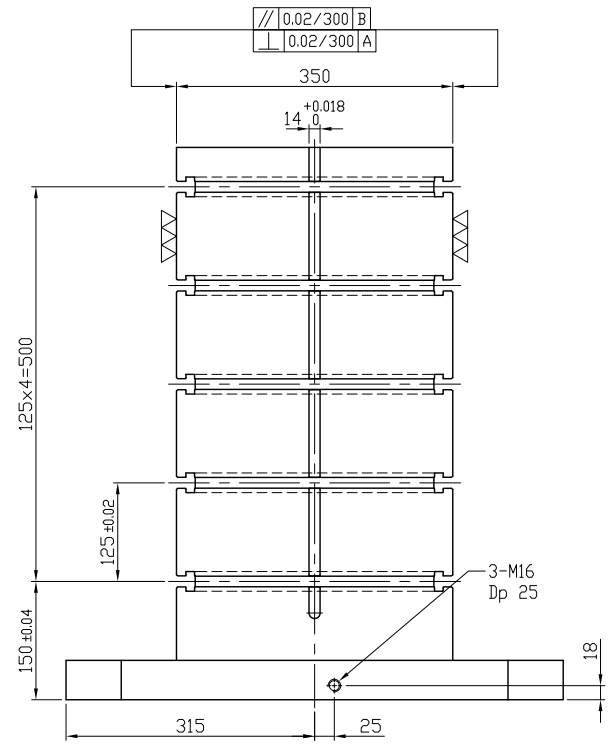
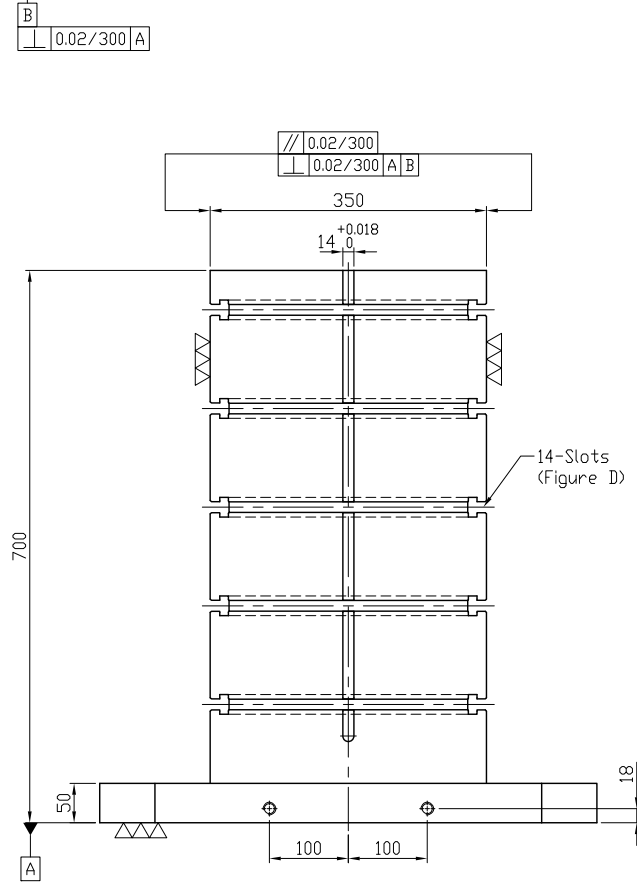
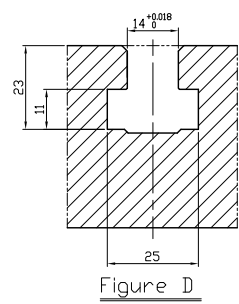
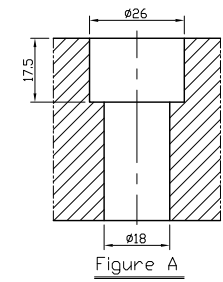
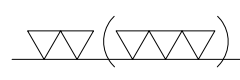
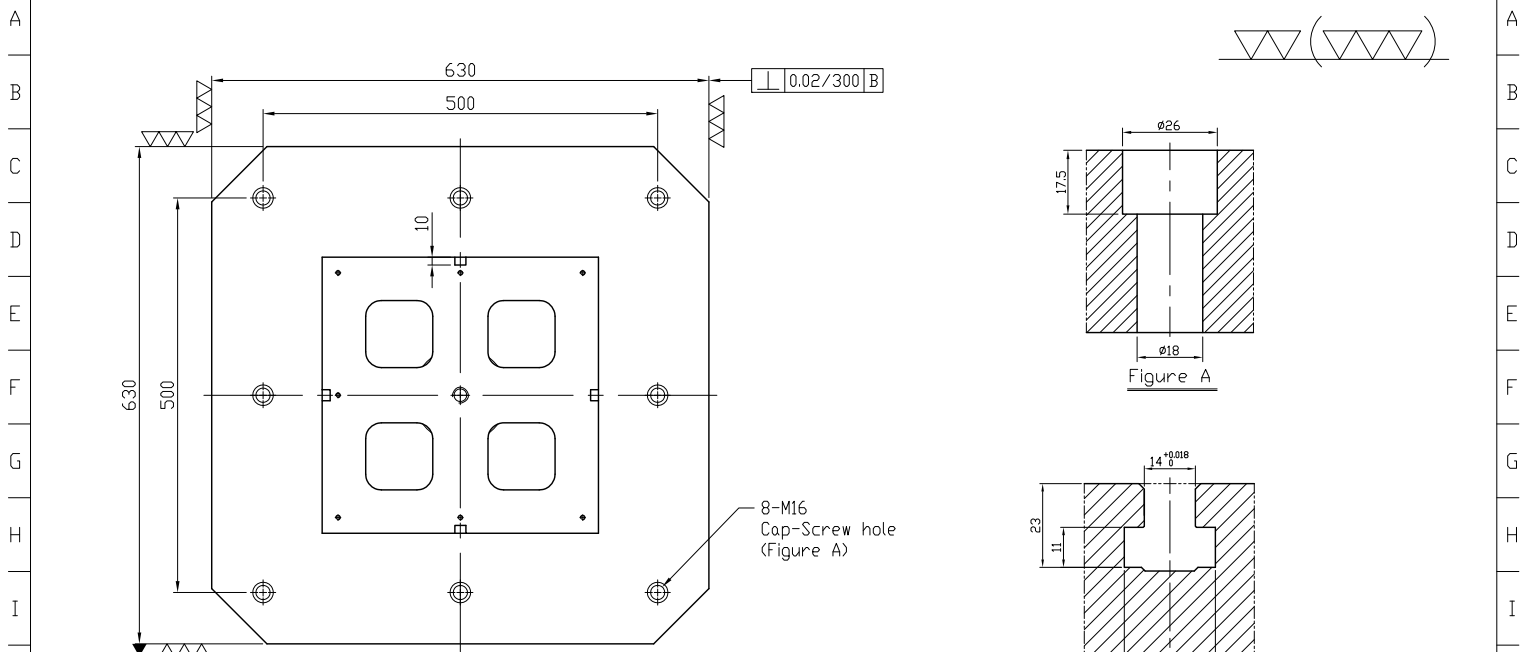

NW:375KG

*Edge chamfered C2

Material FC300		Heat treatment Annealing Process		Surface treatment			
Drafted by S.C.H	Checked by	Approved by		Scale 1/1	Date 2011.10.19	Sheet 1/1	Edition A
			TITLE SQUARE TOOLING COLUMN				
			DWG.ND. BP09-630630-0700-14				

1 2 3 4 5 6 7 8 9 10 11 12 13 14 15 16 17 18 19 20