

6-M16
Cap-Screw hole
(Figure A)

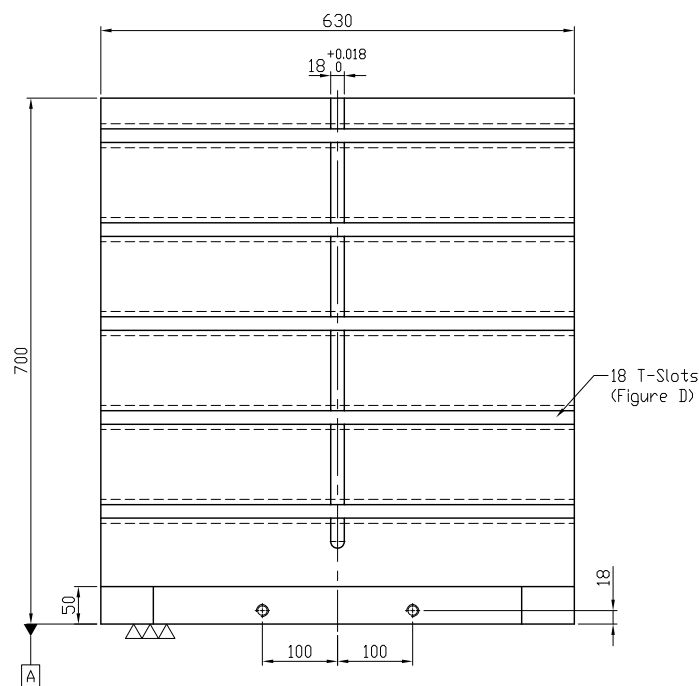

18 T-Slots
(Figure D)

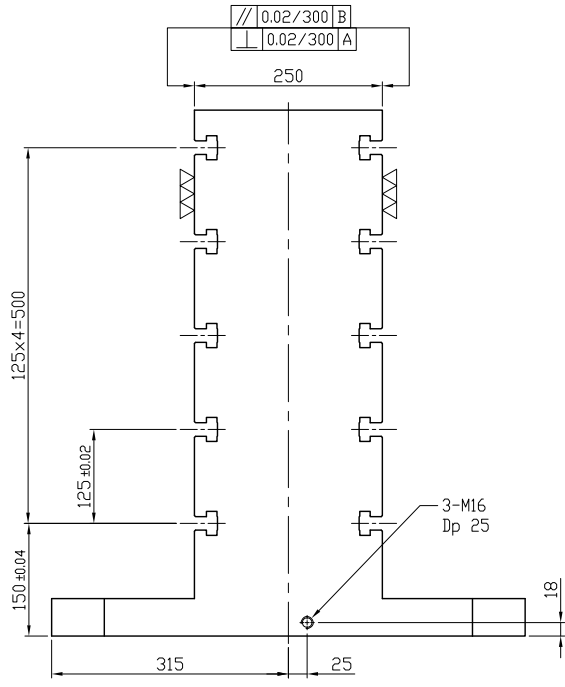

3-M16
Dp 25

*Edge chamfered C2

NW:430KG

Material FC300		Heat treatment Annealing Process		Surface treatment			
Drafted by S.C.H	Checked by	Approved by	Scale 1/1	Date 2011.10.19	Sheet 1/1	Edition A	
 LEAVE INDUSTRIAL CO., LTD.			TITLE DOUBLE SIDED TOOLING COLUMN				
			DWG.ND. BP12-630630-0700-18				