

4-M16  
Cap-Screw hole  
(Figure A)

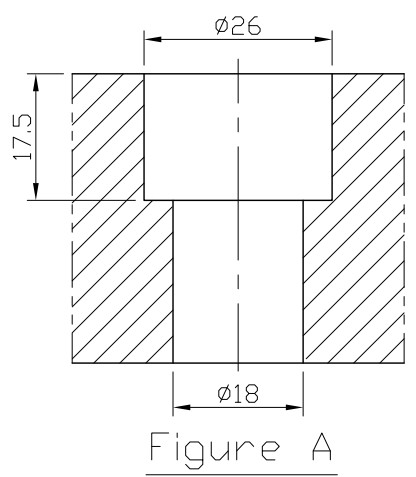

\*Edge chamfered C2

NW:35KG

Material FC300		Heat treatment Annealing Process			Surface treatment		
Drafted by S.C.H	Checked by	Approved by		Scale 1/1	Date 2012.01.12	Sheet 1/1	Edition A
			TITLE SUB-PLATE				
			DWG.NO. BP19-40300-0400-16				