

B
⊥ 0.02/300 A

8-M16
Cap-Screw hole
(Figure A)

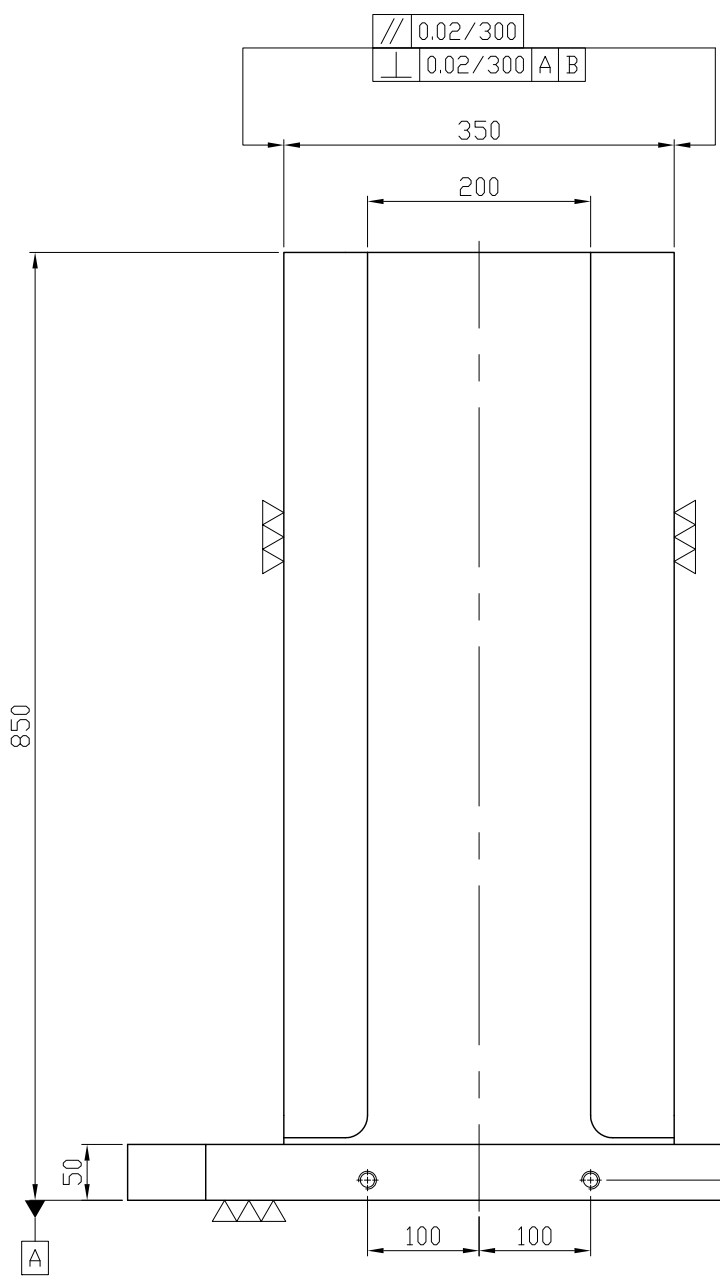

A

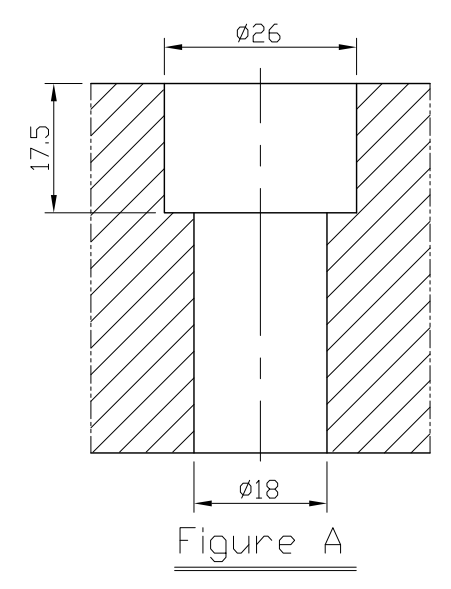
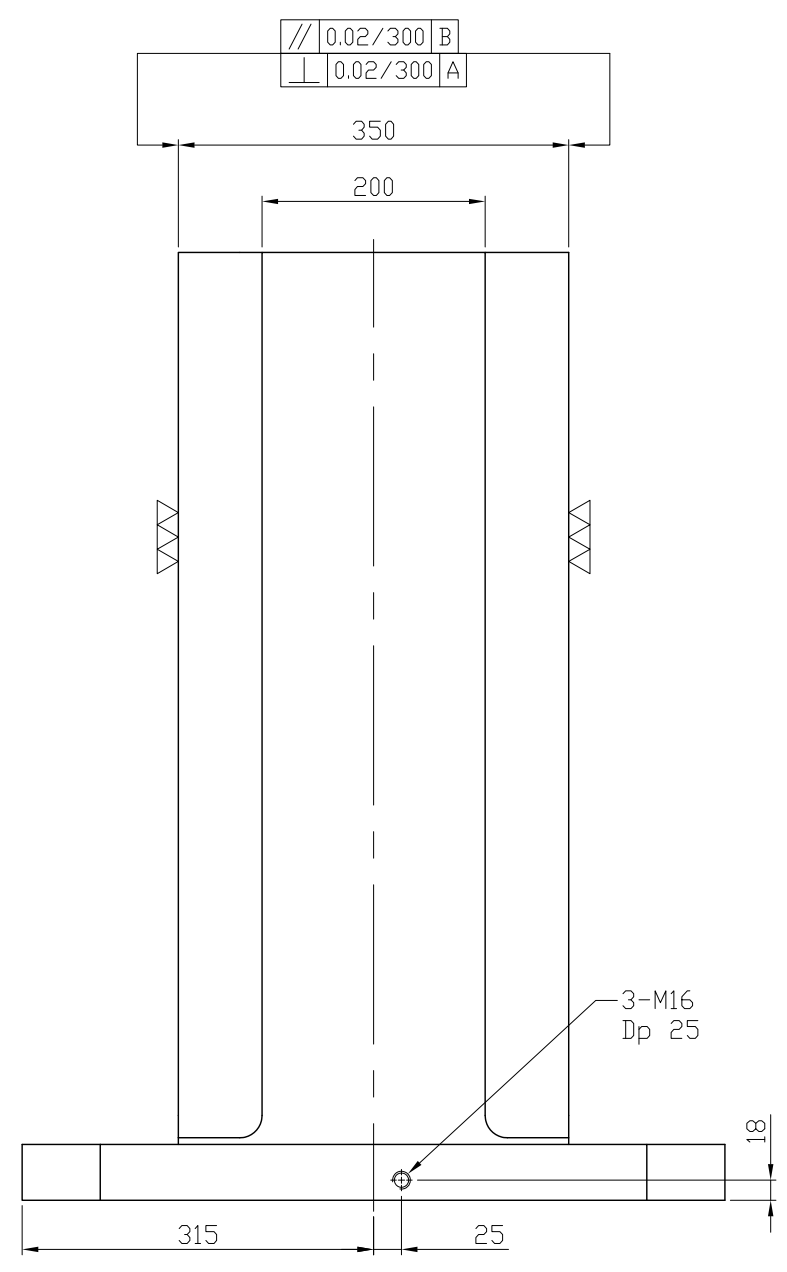

3-M16
Dp 25

*Edge chamfered C2

NW:424KG

Material FC300		Heat treatment Annealing Process		Surface treatment			
Drafted by S.C.H	Checked by	Approved by		Scale 1/1	Date 2011.12.21	Sheet 1/1	Edition A
			TITLE CROSS TOOLING COLUMN				
			DWG.NO. BP29-630630-0850				