

Figure A

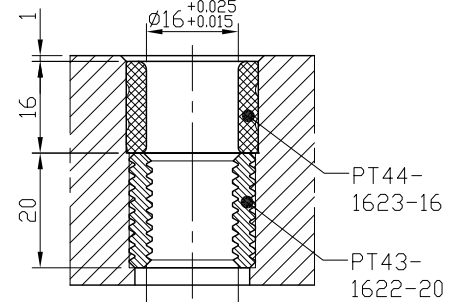
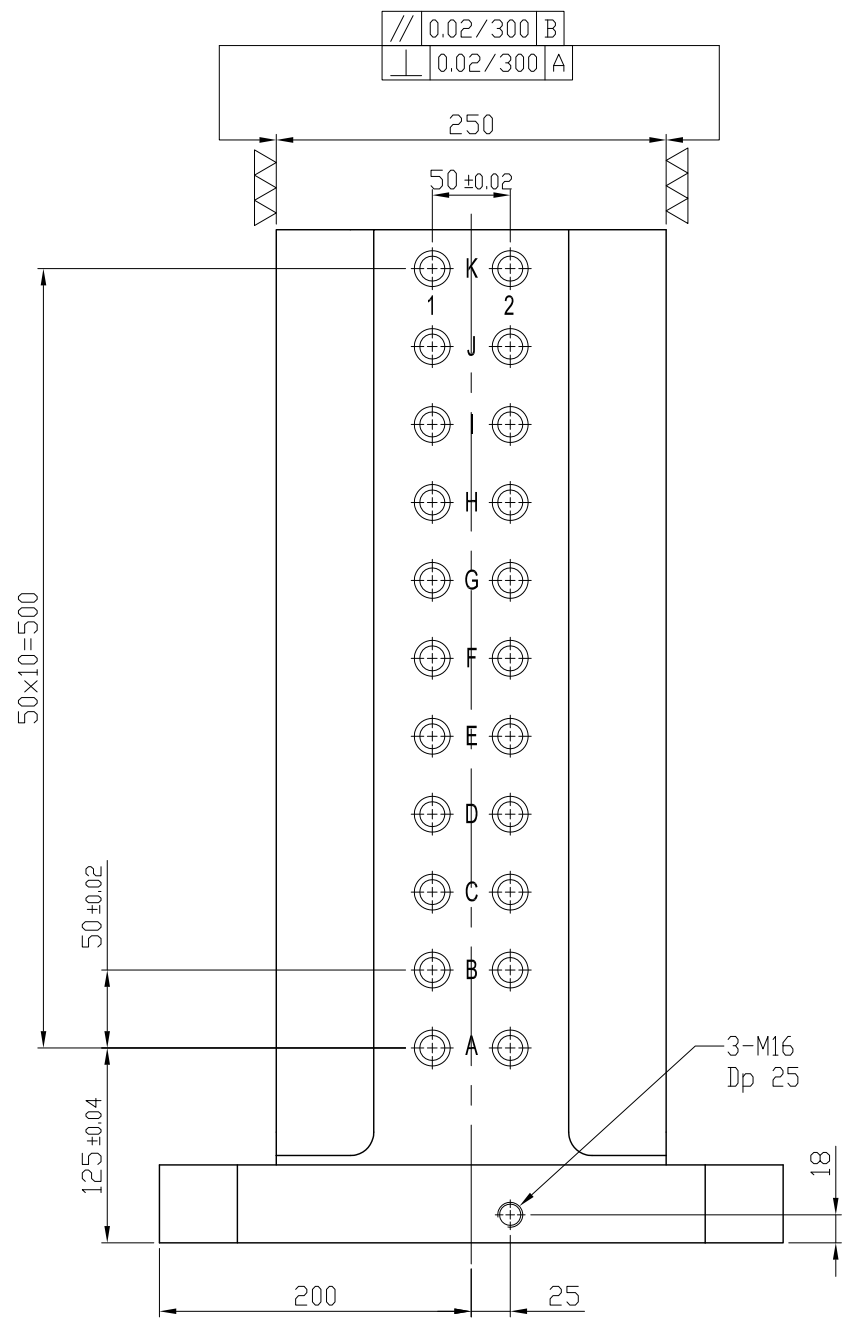
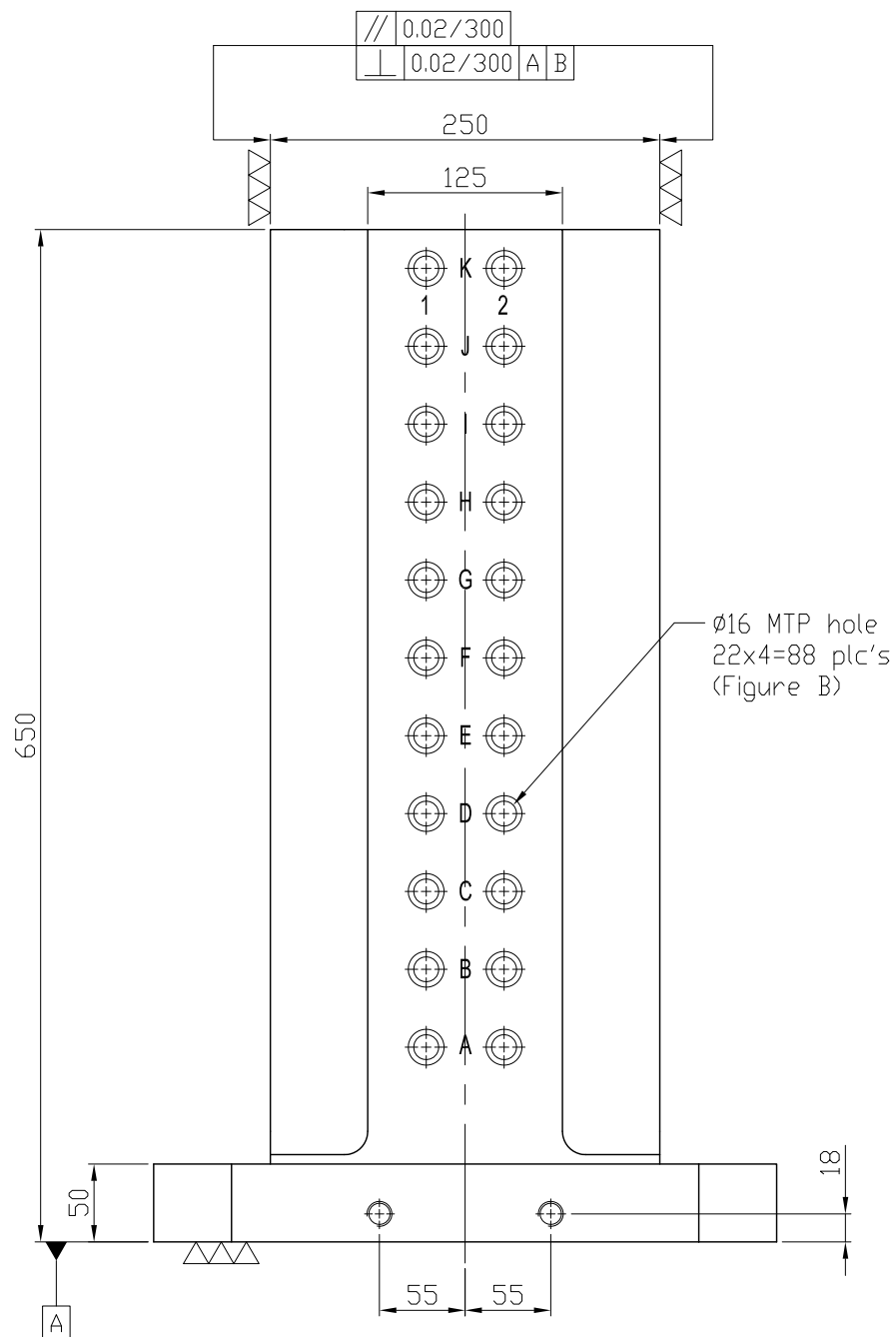

Figure B



*Edge chamfered C2

NW:184KG

Material FC300		Heat treatment Annealing Process			Surface treatment		
Drafted by S.C.H	Checked by	Approved by	Scale 1/1	Date 2011.12.21	Sheet 1/1	Edition A	
			TITLE CROSS TOOLING COLUMN				
			DWG.NO. BP30-400400-0650-16				