

4-M16
Cap-Screw hole
(Figure A)

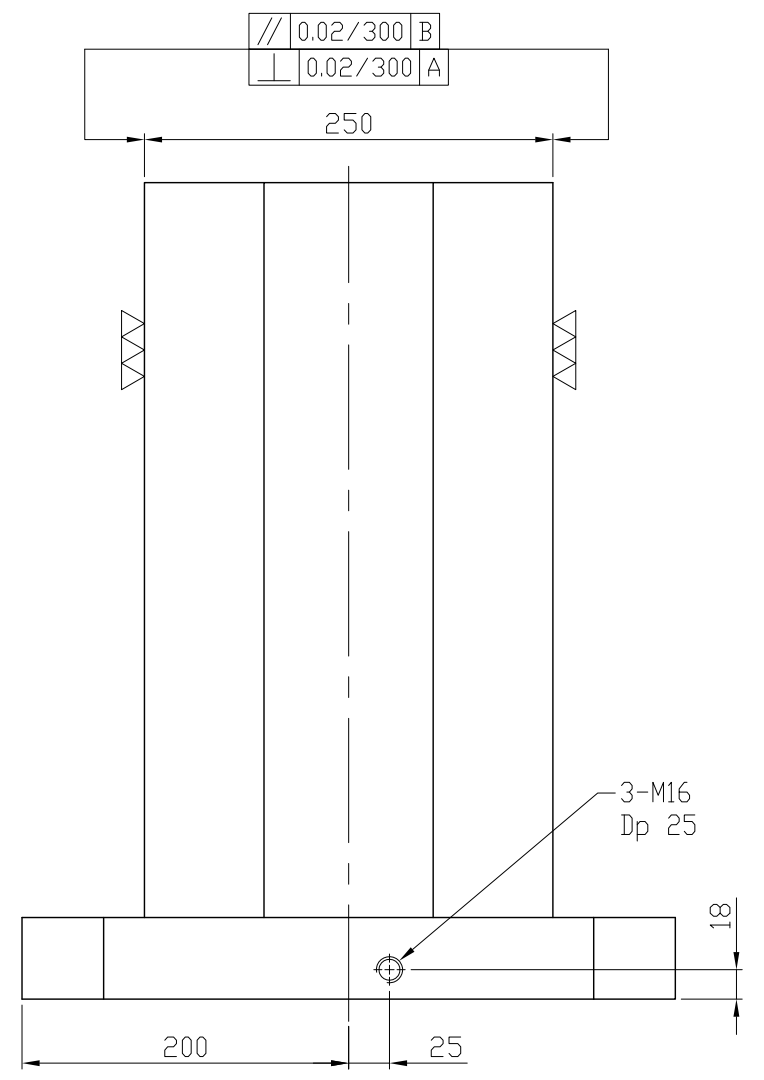
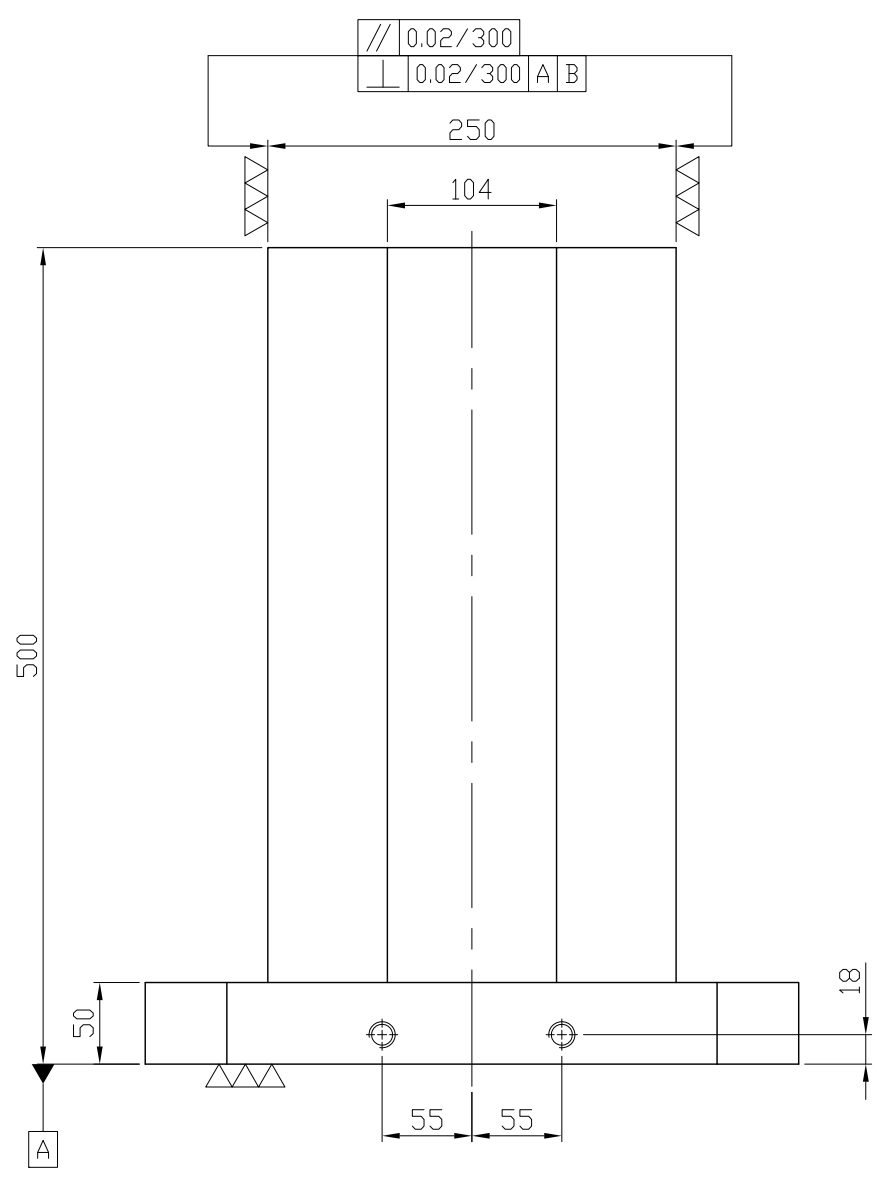

NW:148KG

*Edge chamfered C2

Material FC300		Heat treatment Annealing Process		Surface treatment			
Drafted by S.C.H	Checked by	Approved by		Scale 1/1	Date 2011.12.22	Sheet 1/1	Edition A
			TITLE M/C OCTAGONAL CUBE				
			DWG.NO. BP33-400400-0500				