

CP21

齒型壓板 UNIVERSAL CLAMP

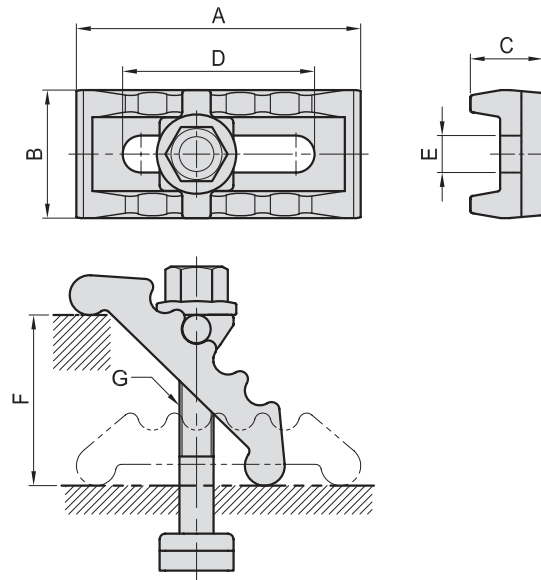

- 材質：S45C 鍛造鋼
- 熱處理：HRC 32°~ 38°
- 表面：染黑處理



MODEL NO.	A	B	C	D	E	F	G	kg
CP21-12100	100	45	26	67.5	13	60	M12-100	1.1
CP21-16125	125	56	33	84.0	18	65	M16-125	2.1