

# SU02

## OFFSET JIG REST BUTTON

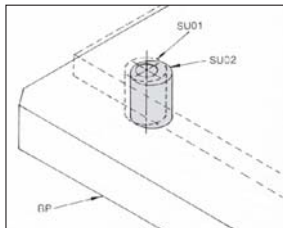

- Material : S45C(JIS) / CK45(DIN)
- Heat treated : HRC 40°.
- Surface finish : Black Oxide.
- Application : Use for supporting and / or positioning workpiece.
- Features : Jig rest buttons are extremely useful as supports, side locator pads, and jig feet.

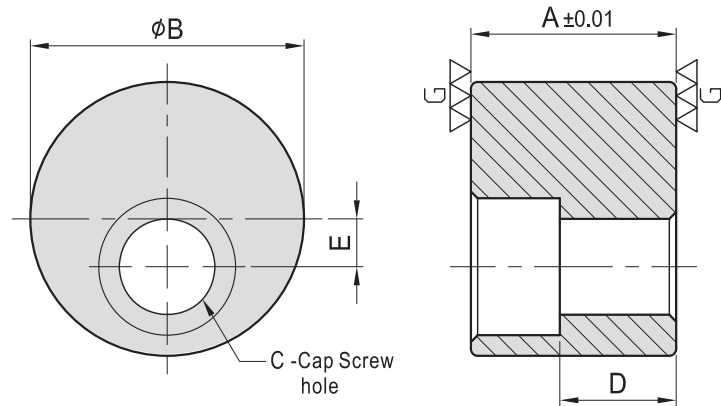

MODEL NO.	A	B	C	D	E	kg
SU02-1230	30	40	M12	17	7	0.24
SU02-1240	40			27		0.32
SU02-1250	50			37		0.41
SU02-1630	30	50	M16	12	10	0.36
SU02-1640	40			22		0.50
SU02-1650	50			32		0.64