

SVF-C

彈性化並列式虎鉗系列

- 材質：工具鋼
- 硬度：HRC 55°以上

高生產力
高靈活度

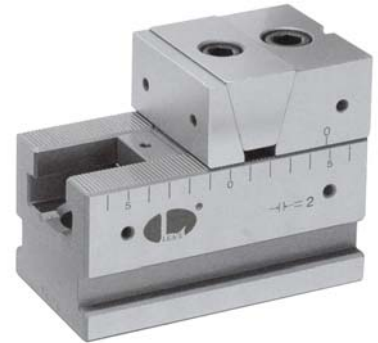
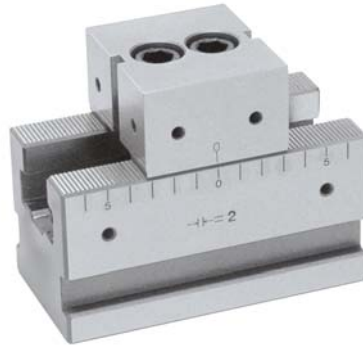

MODEL NO.	kg
SVF-C-5013-100-A	2.0
SVF-C-7214-100-A	5.0
SVF-C-10015-100-A	7.5

MODEL NO.	kg
SVF-C-5013-100-B	2.2
SVF-C-7214-100-B	5.7
SVF-C-10015-100-B	8.5

MODEL NO.	kg
SVF-C-5013-100-C	2.5
SVF-C-7214-100-C	6.2
SVF-C-10015-100-C	9.8

本體

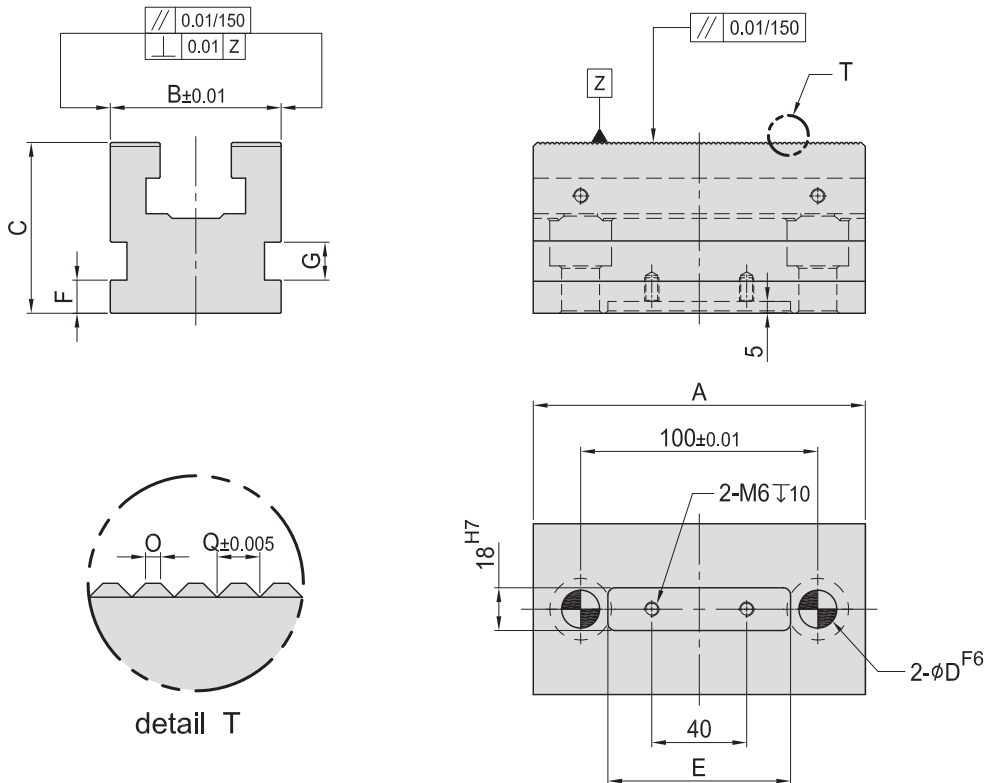

MODEL NO.	A	B	C	D	E	F	G	O	Q	kg
SVF-AB01-5013-100	130	50	50	12	77	10	12	0.50	1.5	1.6
SVF-AB01-7214-100	140	72	72	16	77	14	16	0.70	2.0	4.0
SVF-AB01-10015-100	148	100	72	16	77	14	16	0.85	2.5	5.8