

SU22

SUPPORT JACK

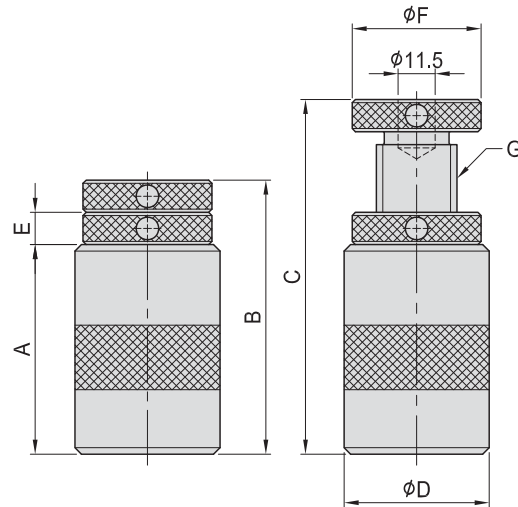

- Material : S45C(JIS), heat treated
- Surface finish : Black Oxide.



MODEL NO.	A	B-C	D	E	F	G	kg	KN
SU22-S050	21	37~50	40	8	35	Tr20x3	0.29	72
SU22-S070	34	50~70					0.40	
SU22-S100	50	70~100	45	10	40	Tr25x4	0.72	135
SU22-S150	76	100~150	50	12	45		1.30	
SU22-S250	120	150~250	60	15	50	Tr28x5	2.90	155
SU22-S300	170	200~300					3.50	