

14 T-Slots  
(Figure D)

6-M16  
Cap-Screw hole  
(Figure A)

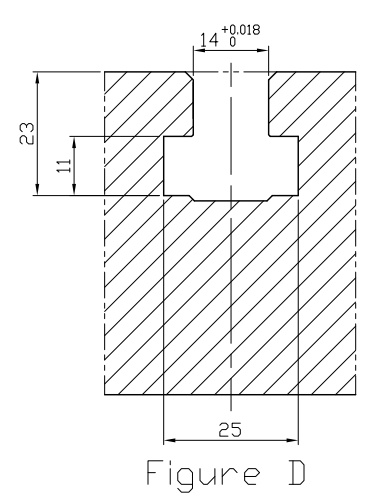
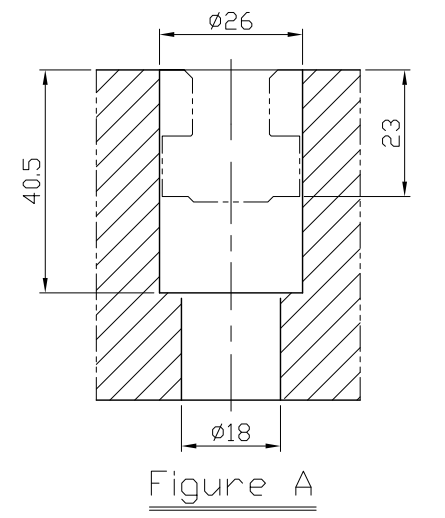
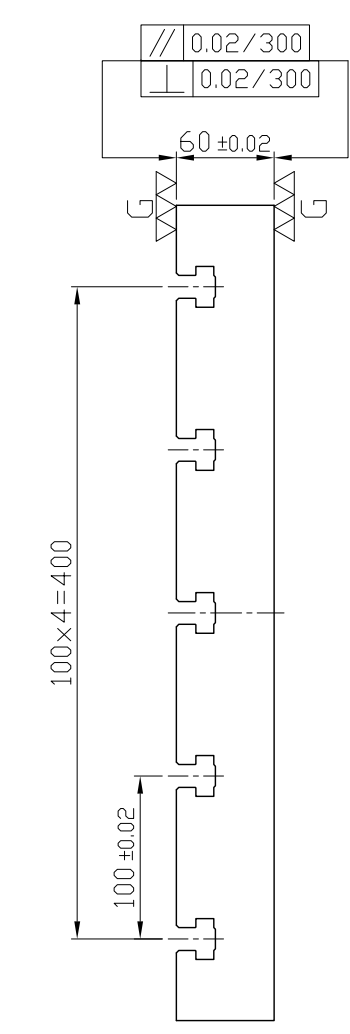
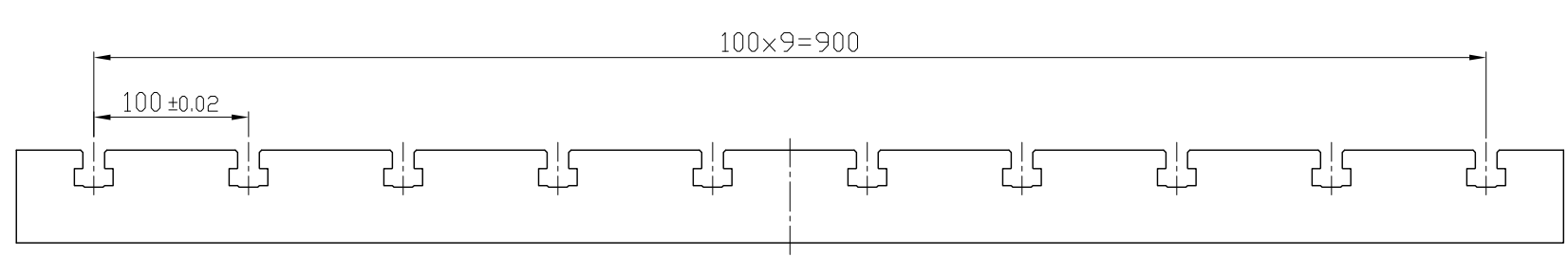

NW:198KG

\*Edge chamfered C2

Material FC300		Heat treatment Annealing Process		Surface treatment		
Drafted by S.C.H	Checked by	Approved by	Scale 1/1	Date 2011.10.15	Sheet 1/1	Edition A
			TITLE M/C BASE PLATE			
			DWG.ND. BP03-60500-1000-14			