

1 2 3 4 5 6 7 8 9 10 11 12 13 14 15 16 17 18 19 20

A B C D E F G H I J K L M N O P Q R S T U V W X Y Z AA AB

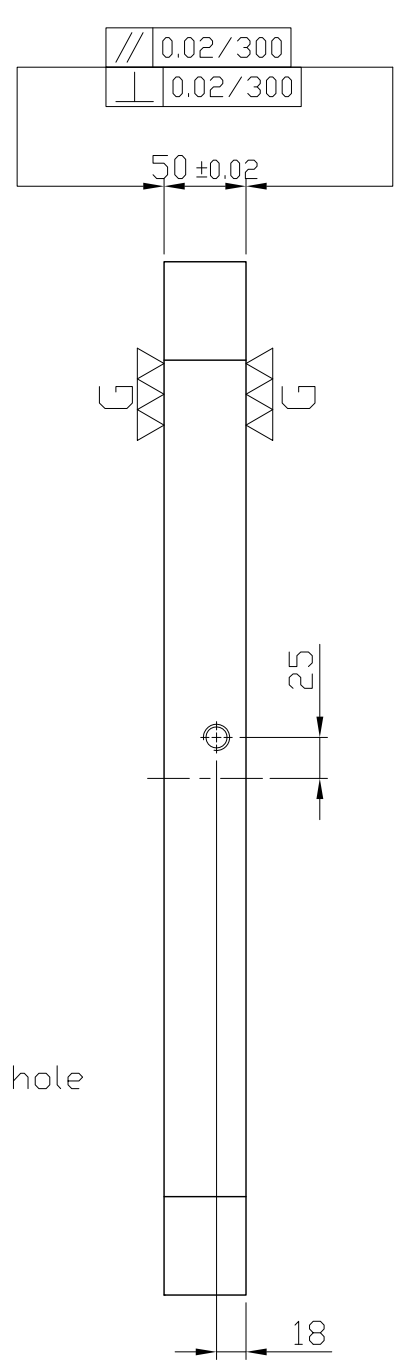

8-M16
Cap-Screw hole
(Figure A)

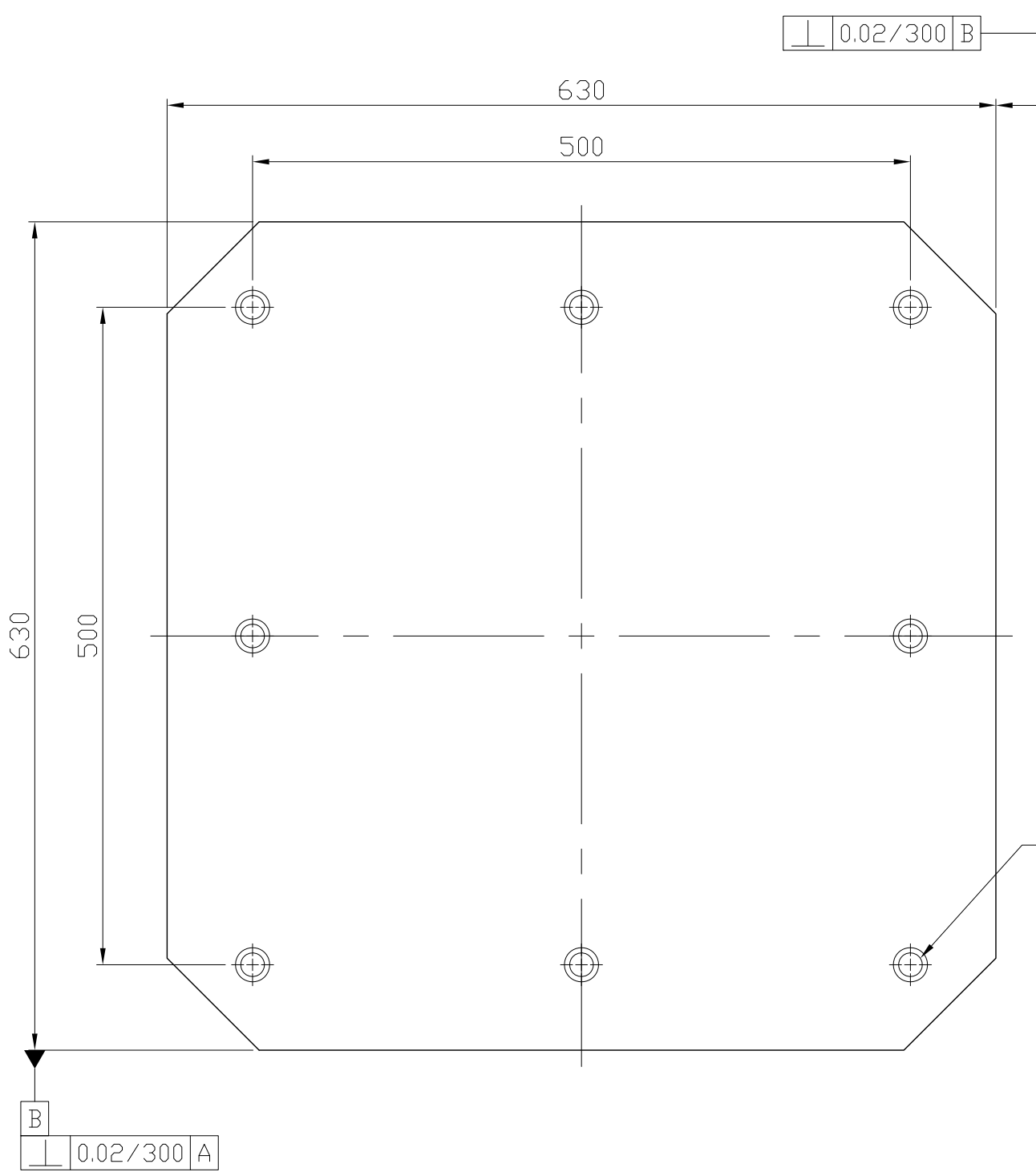
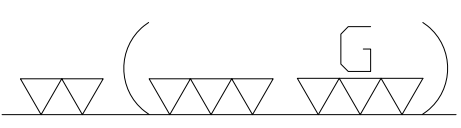
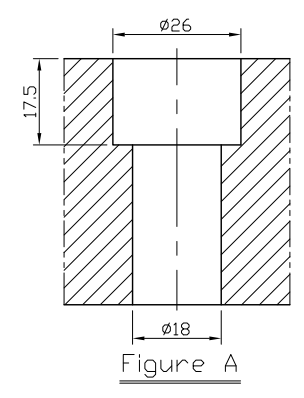
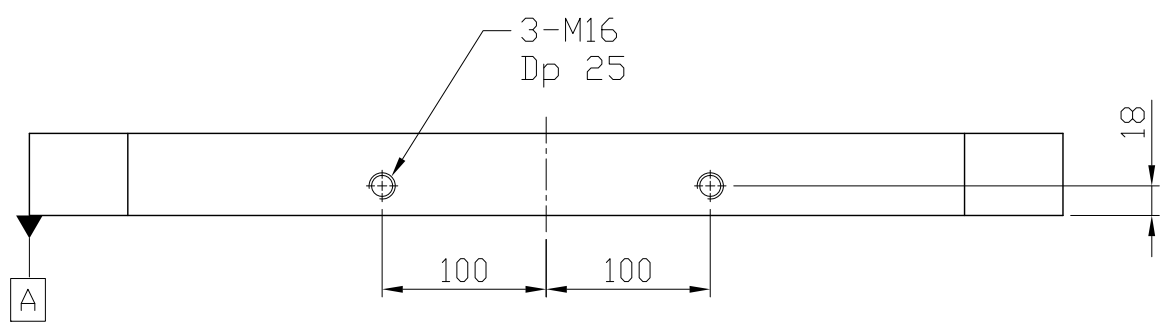

NW:140KG

*Edge chamfered C2

Material FC300		Heat treatment Annealing Process			Surface treatment			
Drafted by S.C.H	Checked by	Approved by		Scale 1/1	Date 2011.10.19	Sheet 1/1	Edition A	
			TITLE M/C BASE PLATE					
			DWG.ND. BP04-50630-0630					

1 2 3 4 5 6 7 8 9 10 11 12 13 14 15 16 17 18 19 20

A B C D E F G H I J K L M N O P Q R S T U V W X Y Z AA AB