

1 2 3 4 5 6 7 8 9 10 11 12 13 14 15 16 17 18 19 20

A B C D E F G H I J K L M N O P Q R S T U V W X Y Z AA AB

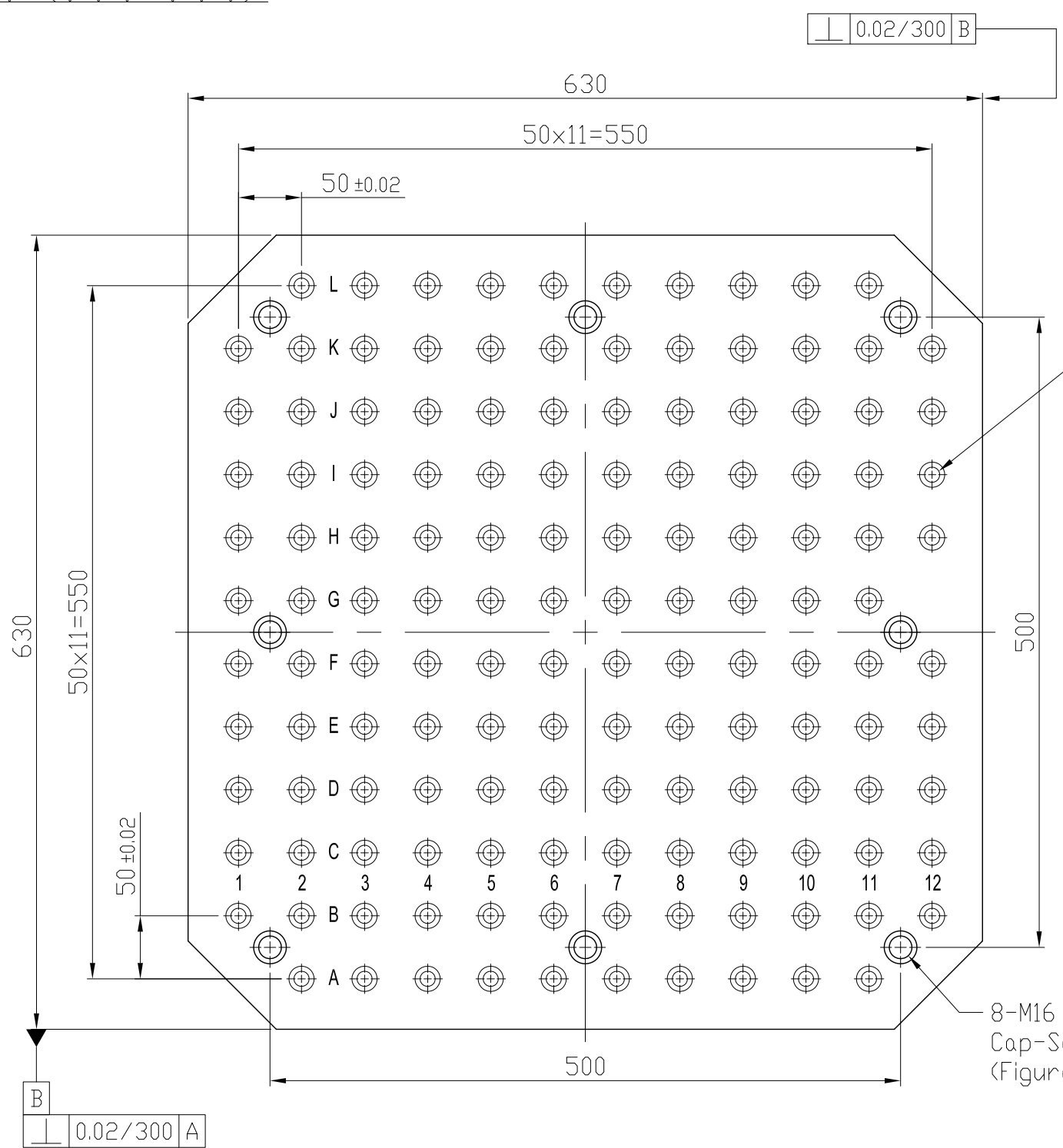
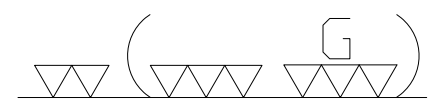

139- $\phi$ 12  
MTP hole  
(Figure B)

8-M16  
Cap-Screw hole  
(Figure A)

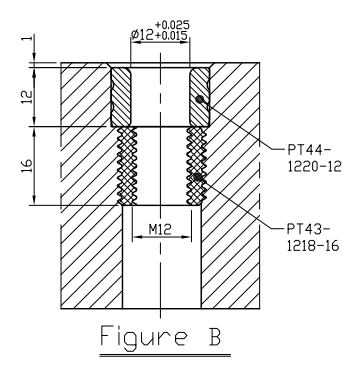
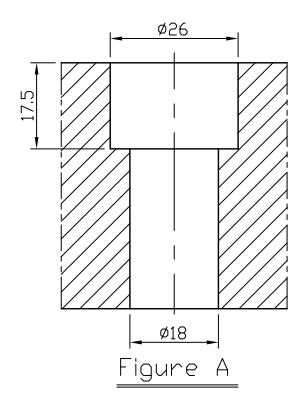
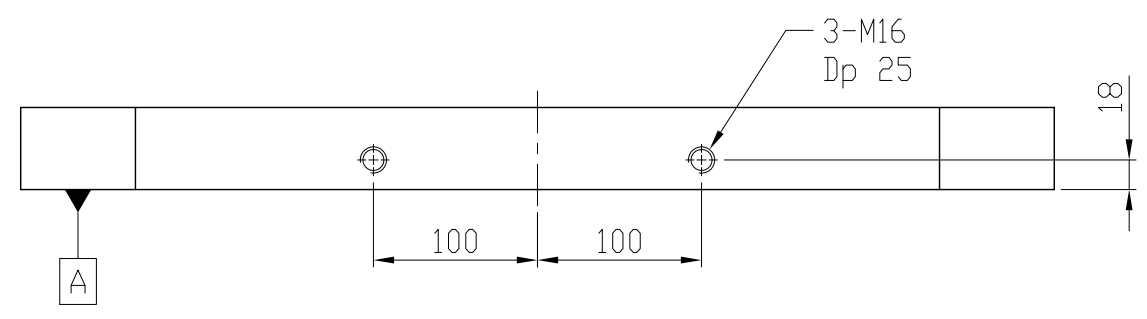
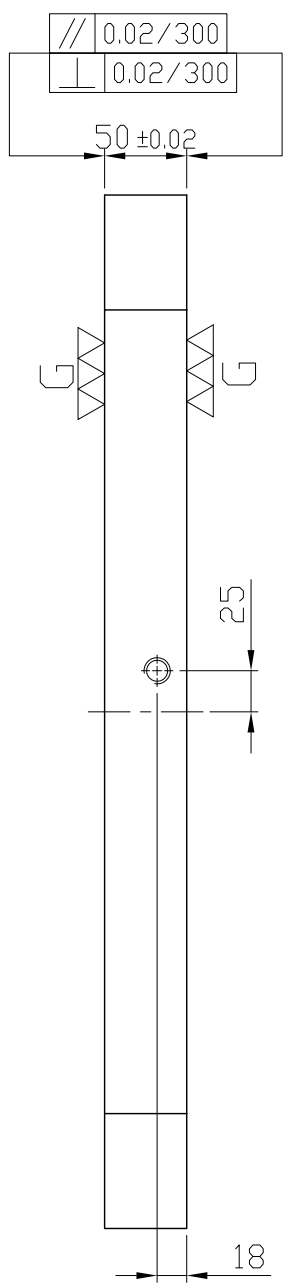

\*Edge chamfered C2

NW:135KG

Material FC300		Heat treatment Annealing Process			Surface treatment		
Drafted by S.C.H	Checked by	Approved by		Scale 1/1	Date 2011.10.19	Sheet 1/1	Edition A
			TITLE M/C BASE PLATE				
			DWG.NO. BP05-50630-0630-12				

1 2 3 4 5 6 7 8 9 10 11 12 13 14 15 16 17 18 19 20

A B C D E F G H I J K L M N O P Q R S T U V W X Y Z AA AB