

8-M16
Cap-Screw hole
(Figure C)

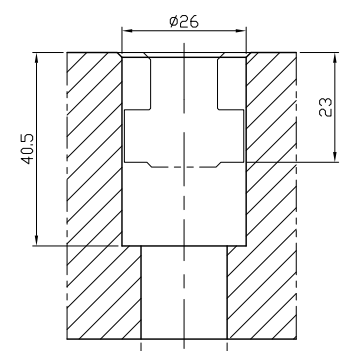
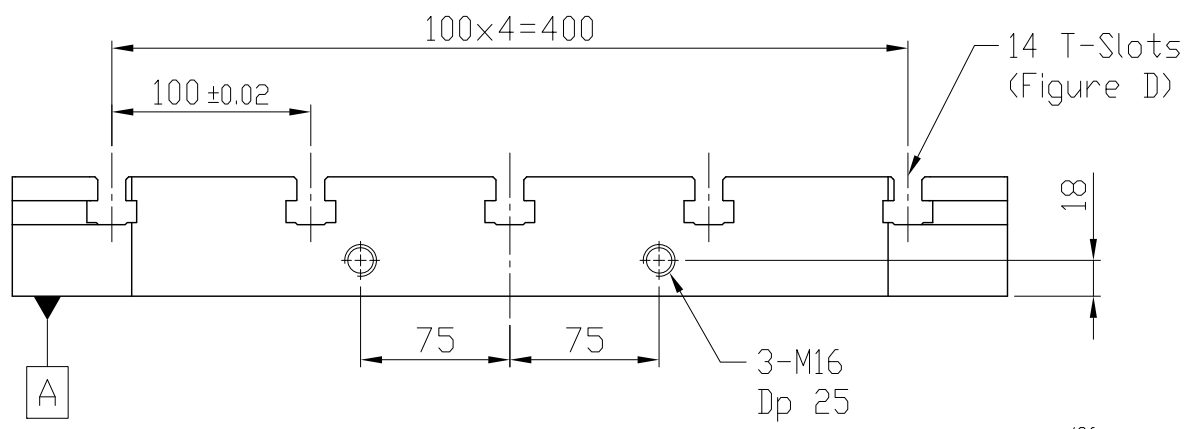

Figure C

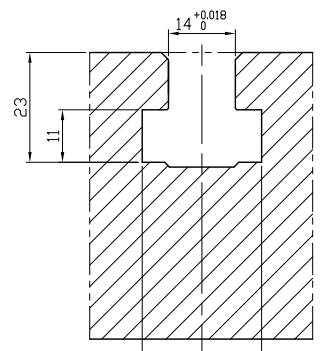

Figure D

NW:90KG

*Edge chamfered C2

Material FC300		Heat treatment Annealing Process		Surface treatment		
Drafted by S.C.H	Checked by	Approved by	Scale 1/1	Date 2011.10.19	Sheet 1/1	Edition A
			TITLE M/C BASE PLATE			
			DWG.NO. BP06-60500-0500-14			