

Figure A

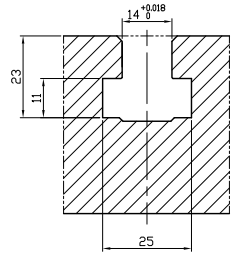
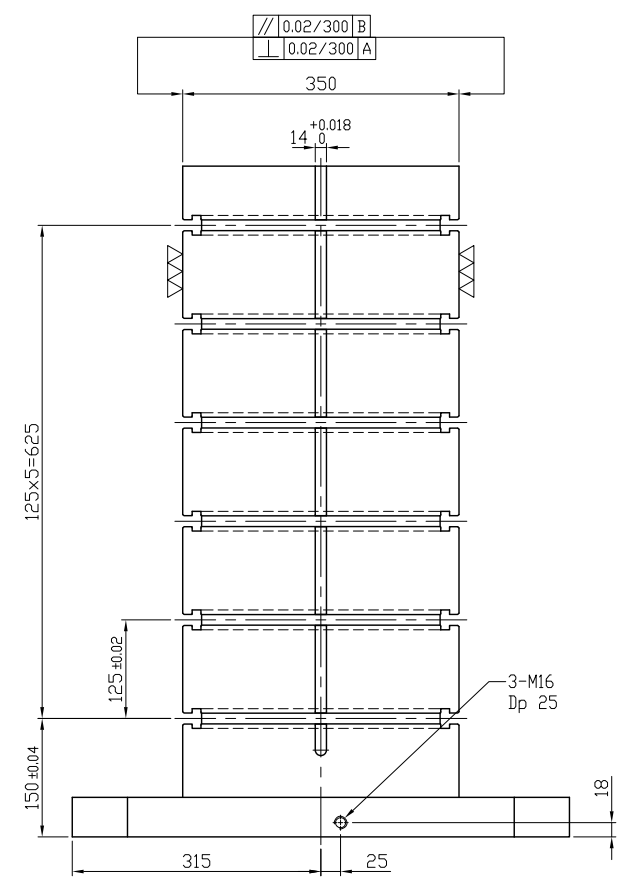
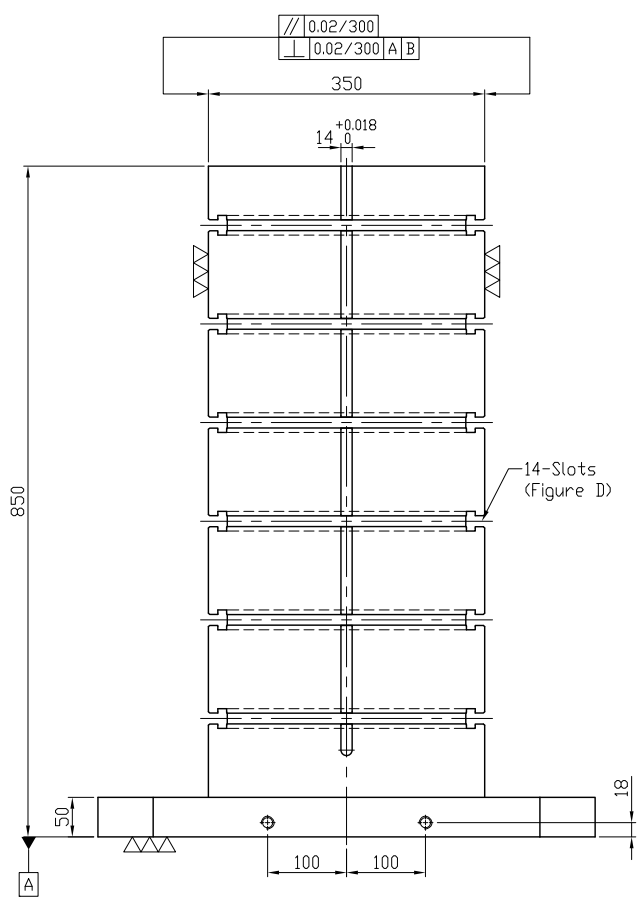

Figure D

8-M16
Cap-Screw hole
(Figure A)



14-Slots
(Figure D)

3-M16
Dp 25

*Edge chamfered C2

NW:435KG

Material FC300		Heat treatment Annealing Process		Surface treatment			
Drafted by S.C.H	Checked by	Approved by		Scale 1/1	Date 2011.10.19	Sheet 1/1	Edition A
			TITLE SQUARE TOOLING COLUMN				
			DWGNO. BP09-630630-0850-14				