

Figure A

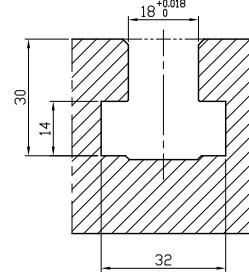
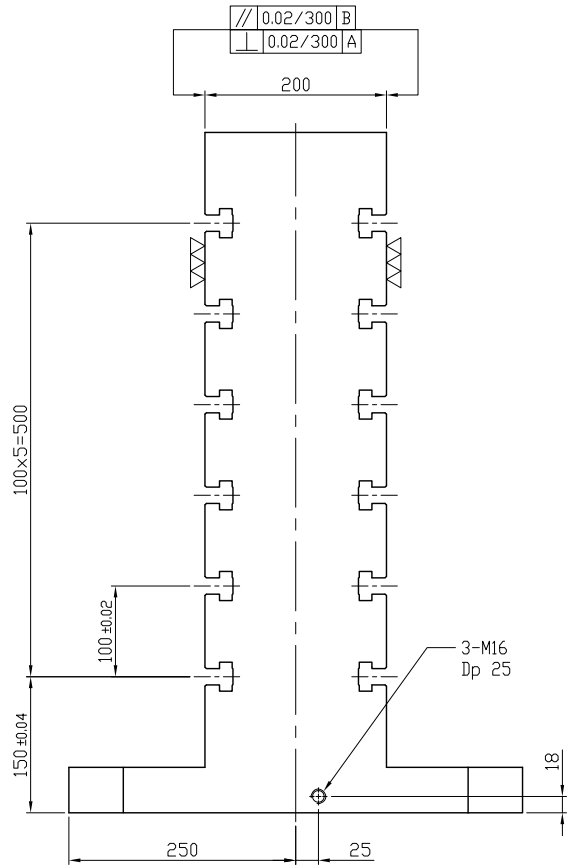
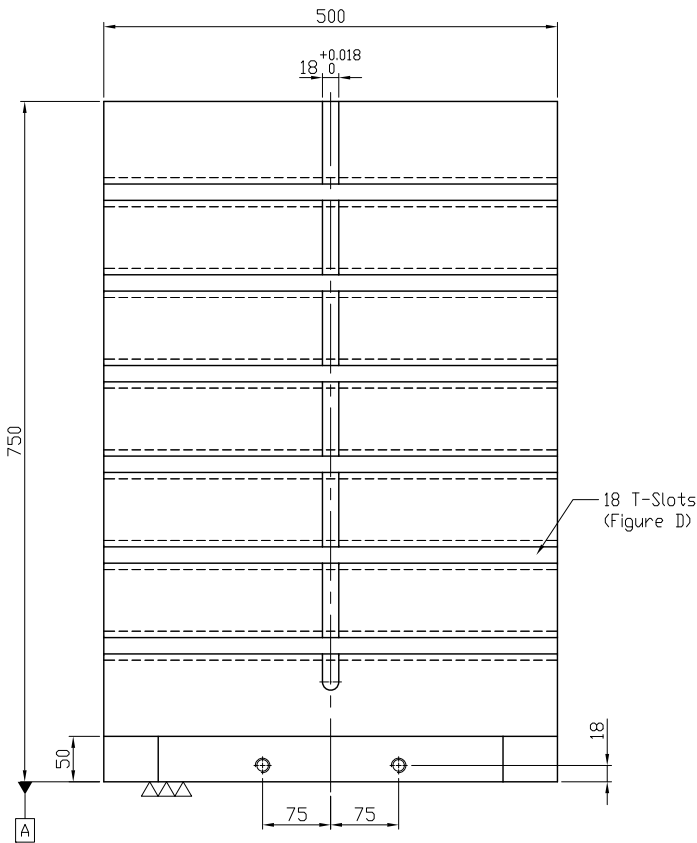



Figure D



*Edge chamfered C2

NW:325KG

Material FC300		Heat treatment Annealing Process			Surface treatment		
Drafted by S.C.H	Checked by	Approved by	Scale 1/1	Date 2011.10.19	Sheet 1/1	Edition A	
 LEAVE INDUSTRIAL CO., LTD.			TITLE DOUBLE SIDED TOOLING COLUMN				
			DWG.ND. BP12-500500-0750-18				